



UNIK 5000 Series Pressure Sensors

For Industrial Leak Test Applications



GE's Druck UNIK 5000 is a high performance and configurable sensor series that is ideal for pressure decay measurements in industrial leak detection applications. The use of in-house Druck silicon technology and analogue circuitry enables a best in class performance for speed, stability and durability.



The Growing Demands on Leak Detection Systems in Today's Manufacturing Processes

Whilst leak testing – also known as pressure or vacuum testing - is a relatively niche area of engineering, it plays a vital role in hundreds of different applications across a wide array of industries and sectors. The final application can vary from medical applications to automotive plants, industrial manufacturers to packaging plants; however the needs of the end user are the same when sourcing leak test equipment.

Speed and accuracy are the two vital components of any leak test equipment, in a process manufacturing industry where productivity is key. A reduction in test cycle time can have enormous benefits, whether that be quickly identifying faults before larger scale production starts, avoiding costly mistakes, or increasing the overall number of units tested in the same time period.

Manufacturers of leak test equipment need to ensure their solution remains competitive by offering the right solution to meet the customer's needs.

The sensor is a key component in any leak test equipment and will have a major impact on the overall performance of the test equipment. Selecting the right sensor and optimising the measuring system around that sensor will determine many of the parameters that the final customer is looking for and ultimately how fast and accurate the equipment is at detecting leaks.



Summary

- Manufacturers need to constantly improve the quality & performance of their end products
- Leak Testing is a vital quality assurance step in many manufacturing process
- Leak Test Equipment OEMs must constantly keep improving equipment's performance
- Pressure sensor is a key driver of the performance of any leak test system

Pressure Decay Leak Detection

Leak detection is used when the value of the leakage rate is generally non-quantifiable. The pressure decay method measures the decrease in pressure of an object and is used in a wide range of applications. The resolution of the measurement is critical to the speed of the test and a sensor with low noise can operate at a higher resolution and therefore determine a positive result faster.

Relative Pressure - Standard

Pressure decay leak detection testing instruments are extremely useful for checking components that have relatively small volumes. The component is pressurized with air and the pressure transducer monitors the pressure for negative changes. Any pressure drop indicates a leak. The test is very fast, a matter of seconds, and is therefore popular in high-volume industries such as automotive components, castings, medical devices and consumer goods.

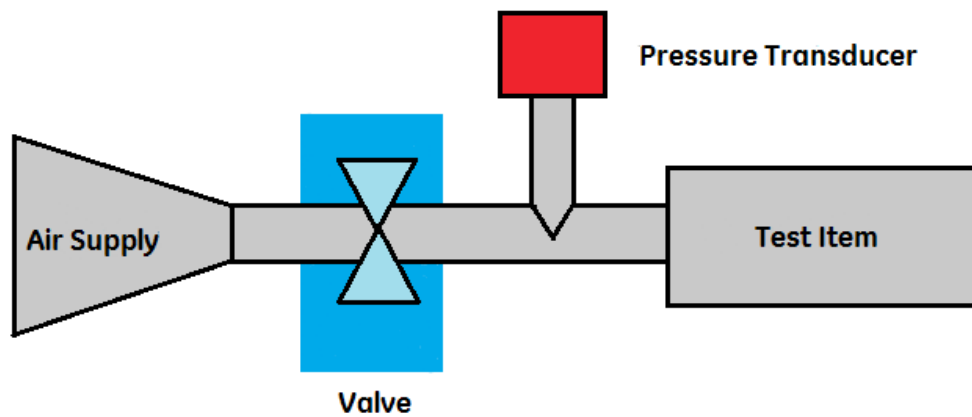

Pressure Difference - High Resolution

A stable reference part with a volume and a similar pneumatic characteristic is arranged to be at the same pressure as the part under test. Time-related changes in the pressure of the test volume are used to measure the value of any leakage. A differential pressure transducer is connected across the two volumes. The pressure measurement is dependent upon the sensitivity of the differential pressure transducer at the test pressure.

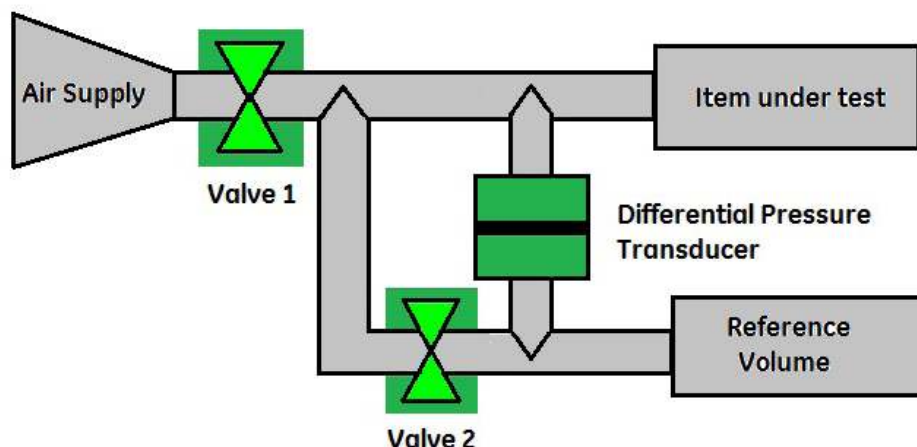

Why Use GE's UNIK 5000 Series

The Pressure sensor is the heart of a leak testing system and will drive the performance of the final piece of equipment. GE's Druck business has been manufacturing high performance piezo resistive pressure sensors since 1972 and has developed a world class expertise in high performance, high stability, fast responding and high quality pressure sensors.

The UNIK 5000 series of sensors is GE's latest pressure sensor range and is ideally suited for leak test applications. Today, we supply sensors to some of the biggest and best known leak test equipment manufacturers who trust GE Druck sensors to deliver the quality and performance their customers are expecting.

1. Fast Speed of Response

GE's in-house silicon manufacturing and design means UNIK 5000 series sensors have a frequency response to 3.5 kHz to support high speed processes.

2. High Accuracy and Stability

By making our own silicon diaphragms and ensuring Six Sigma manufacturing quality, UNIK 5000 sensors deliver accuracy to $\pm 0.04\%$ FS and stability to $\pm 0.05\%$ FS typical ($\pm 0.1\%$ FS maximum) per year

3. Supply Chain Accuracy

Working in a fast paced environment, we understand the importance of fast and punctual delivery for OEM customers. UNIK 5000 series sensors can be delivered on a 1 to 2 week lead time from our factory.

4. Highly Configurable Solution

The UNIK 5000 series of sensors has over 300,000 configurable options covering absolute and gauge from 70 mbar (1 psi) to 700 bar (10,000 psi) and a range of connectors, outputs and cables.



1 Sensor

500,000 unique combinations

The UNIK 5000 series of pressure sensors are built using GE's own in-house designed and manufactured silicon modules and analogue circuitry to ensure the highest performance and build quality in a pressure sensor. With over 500,000 configurations, the UNIK 5000 series is trusted by thousands of customers in hundreds of different applications when performance really matters.

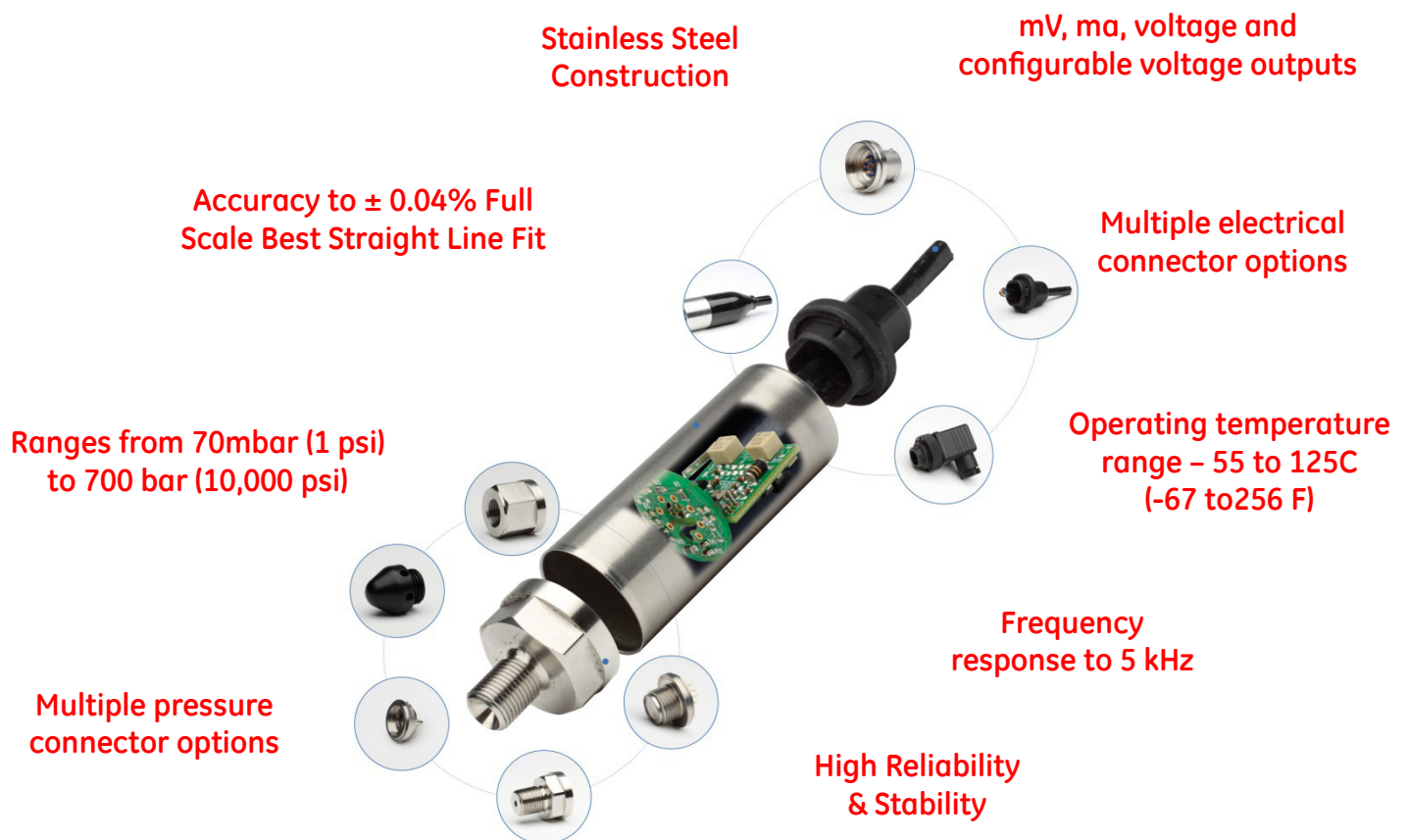

What makes GE Druck Pressure Sensors Different?

GE is one of the only sensor manufacturers to make the silicon sensing element in-house at our own multi-million dollar clean room facility in the UK. This enables us to ensure quality and get better integration between the sensing element and its electronics. Together, this means we can achieve world class levels of accuracy and stability and deliver maximum performance from piezo-resistive silicon.



Case Study

We have had many success stories from companies using the GE Druck's UNIK 5000 series. Our goal is to provide a solution to your problem by offering you the ability to personalise your sensor to meet your specific needs. A global OEM of inspection equipment selected GE Druck's UNIK 5000 series for its multi-inspection machine that checked the quality and accuracy of glass bottles in a production line. Here is their story.

The Customer

A major global OEM that manufactures inspection solutions for the hollow glass industry.

The Problem

The global OEM makes a servo driven multi-inspection machine that is used to control and check round and non-round glass bottles on a product line. The test system controls and measures the rise in pressure when air is injected inside the glass bottle. If the pressure increases to a certain level, the bottle passes the quality test. If not the bottle is returned to production. In this leak test application, speed and accuracy of operation were important. They needed a pressure sensor with sufficient speed, accuracy and noise level performance to meet their customer's high specification.

The Solution

The PDCR5011-TA-A3-CA-HO-PJ 0-70 mbar option in the UNIK5000 series was chosen because of its' resolution, low noise, speed of response, accuracy and repeatability. This final pressure test is very important because it's the final quality test before shipping glass bottles to batching plant where they are filled with beer, water or chemicals etc. Poor final control could have a large financial impact due to lost production.



Ordering Information –

visit www.unik5000.com for the online tool

Select each individual component to meet your specific needs.

Main Product Variant

PMP Amplified Pressure Transducer
PDCR Digital Pressure Sensor – Digital Output
PTX 4-20mA Pressure Transmitter

Product Series

5 UNIK 5000

Diameter and Material

0 25MM Stainless Steel

Electrical Connector

- 0 No Electrical Connector
- 1 Cable Gland (Polyurethane Cable)
- 2 Raychem Cable
- 3 Polyurethane Cable (Depth)
- 4 Hytrel Cable (Depth)
- 6 MIL-C-26482 (6-pin Shell Size 10) (Mating connector not supplied)
- 7 DIN 43650 Form A Demountable (Mating connector supplied)
- A Demountable MIL-C-26482 (6-pin Shell Size 10) (Mating connector not supplied)
- C 1/2" NPT Conduit (Polyurethane cable)
- D Micro DIN (9.4 mm Pitch) (Mating connector supplied)
- E MIL-C-26482 (6 pin Shell Size 10) Alternative Wiring (Mating connector not supplied)
- F Demountable MIL-C-26482 (6 pin Shell Size 10) Alternative Wiring (Mating connector not supplied)
- G M12 x 1 4-pin male (Mating connector not supplied)

Electronics Option

- 0 mV Passive 4-wire (PDCR)
- 1 mV Linearised 4-wire (PDCR)
- 2 4 to 20 mA 2-wire (PTX)
- 3 0 to 5 V 4-wire (PMP)
- 4 0 to 5 V 3-wire (PMP)
- 5 1 to 6 V 3-wire (PMP)
- 6 0 to 10 V 4-wire (PMP)
- 7 0.5 to 4.5 V Ratiometric 3-wire (PMP)
- 8 Isolated/Configurable 4-wire (PMP)

Accuracy

- A1 Industrial
- A2 Improved
- A3 Premium

Calibration

- CA Zero/Span Data
- CB Room Temperature
- CC Full Thermal

Hazardous Area Approval

- H0 None
- H1 IECEx/ATEX Intrinsically Safe 'ia' Group IIC
- H2 IECEx/ATEX Intrinsically Safe 'ia' Group I
- H3 IECEx/ATEX Protected by Enclosure 'ta' Group III
- HA H1 + H2
- HB H1 + H2 + H3

Pressure Connector

- PA G1/4 Female Note 3
- PB G1/4 Male Flat
- PC G1/4 Male 60 degree Int Cone
- PD G1/8 Male 60 degree Int Cone
- PE 1/4 NPT Female Note 3
- PF 1/4 NPT Male
- PG 1/8 NPT Male
- PH M20x1.5
- PJ M14x1.5 60° Internal Cone
- PK M12x1 Internal Cone
- PL 7/16-20 UNJF Male 74° External Cone
- PN G1/2 Male via Adaptor Note 3
- PR 1/2 NPT Male via adaptor Note 3
- PS 1/4 Swagelok Bulkhead
- PT G1/4 Male Flat Long
- PU 7/16-20 UNF Long 37 degree flare tip
- PV 7/16-20 UNF Female
- PW Depth Cone (G1/4 Female open face)
- PX 7/16-20 UNF Male Short Flat
- PY 3/8-24 UNJF
- PZ M10 x 1 80° Int Cone
- RB G1/4 Male Flat with Snubber

PTX 5 0 7 2 TA A2 CB H0 PA Typical Model Number

For more information, please visit www.gemeasurement.com

Other Pressure Products from GE

GE Measurement & Control is a leading innovator in sensor-based measurement, inspection, asset condition monitoring and radiation measurement solutions that deliver accuracy, productivity and safety to customers in a wide range of industries, including Oil & Gas, Power Generation, Aerospace, Transportation & Healthcare.

Pressure Indicators and Controllers



PACE Series

Test & Calibration Tools



Pressure Calibrators



Multifunction Calibrators



Process Industry Test Tools

High Performance & High Accuracy Pressure Sensors



PTXPRESS Pressure Sensor



Sector specific pressure sensors e.g. oil and gas & aerospace

Calibration Management Software

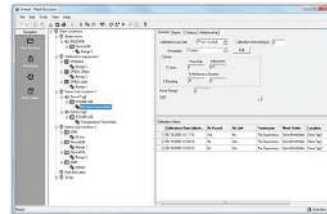

Intecal v10 & 4Sight Calibration Management Software



For more information on the UNIK 5000, please visit our website at www.gemeasurement.com