

THE TEMPERATURE HANDBOOK



A practical guide to temperature measurement, control and calibration using thermocouples, platinum resistance thermometers, thermistors and infra red sensors

Temperature

In 1848, Sir William Thomson (Lord Kelvin) stated the zero principle of dynamics. This principle enabled him to define thermodynamic temperature and to establish an objective method of measuring it.

When two systems are each in thermal equilibrium with a third, they are in thermal equilibrium with each other. This equilibrium is expressed by their equal temperatures. If a conventional value is ascribed to the temperature of a system in a given physical state, other temperatures can be determined by thermodynamic measures.

In 1961, the General Conference on Weights and Measures chose as the standard unit of thermodynamic temperature the Kelvin (K), defined as the degree on the thermodynamic scale of absolute temperatures at which the triple point of water is 273.16K (the equivalent of 0°C). At this temperature ice, water and water vapour can co-exist in equilibrium.

According to this convention the freezing and boiling points of water under atmospheric pressure are respectively 273.15K and 373.15K. The temperature interval measured by one Kelvin is equal to that which measures 1°C.

Without the facilities of highly specialised laboratories, it is extremely difficult to use thermodynamic thermometers (gas and radiation types) and other phenomena are utilised for practical convenience:

- i) Change in electrical resistance with temperature in metals
- ii) thermoelectric activity (e.m.f. produced by thermocouples)

On this basis, resistance thermometers and thermocouples have been developed. In order to define the relationship between temperature and the electrical properties of such sensors, they have to be measured and compared at given temperature values. Temperature scales were devised to this end based on "fixed points", temperatures at which pure elements change their physical states (solid/liquid/gas). Interpolations between these points are made by highly precise thermometers for specified temperature ranges. The international temperature scale -ITS 90 provides the current, practical reference.

Introduction

THE NEW LABFACILITY TEMPERATURE HANDBOOK

A comprehensive reference text and user guide for anyone involved in temperature measurement and control

The new Labfacility Temperature Handbook is a budget priced comprehensive, up to date reference text for users of thermocouples, PRTs and thermistors and associated instrumentation. Detailed enough for engineers and scientists, it is also suitable for technicians and students. Written with practical bias, the handbook contains considerable reference data and basic theory and is therefore of great value as a training aid for those entering the field of temperature measurement and control.

The handy A5 size book contains 139 pages, 40 of them being reference data and uses 65 illustrations. The broad scope of the handbook includes detailed temperature sensor guidance, sensor theory and practice and comprehensive applications guidance. Additional chapters describe temperature control, transmitters, instrumentation and data acquisition and a 40 page reference section carries a wealth of data on thermocouple and platinum resistance thermometry.

This handbook is designed to be of particular value to those technicians and engineers involved with electrical temperature measurement and control. The emphasis is on practical aspects but the basic theory and applications aspects will be of particular interest to students and apprentices.

Information provided in this publication is intended as general guidance and not necessarily deemed definitive. Every effort has been made to ensure the accuracy of information presented but the reader should refer to manufacturer/supplier data and relevant published standards when procuring or using any sensors, materials or equipment.

Specifications and data included in this handbook may be subject to change

© Labfacility Ltd 2006

All rights reserved. This publication may not be reproduced, stored in any retrieval system, or transmitted in any form or by any means, electronic, mechanical, photocopying, recording or otherwise, without the prior permission of the Copyright owner.

Published by:
Labfacility Ltd
Middlesex
UK

Origination and Artwork by:
UKL Technical Services
Angmering
West Sussex. UK

Data Temperature handbook
TH0906 V2.1

INTRODUCTION

1. TEMPERATURE MEASUREMENT USING ELECTRICAL TECHNIQUES	8
2. THERMOCOUPLE THEORY AND PRACTICE.....	10
2.1. BASIC THEORY	10
2.2. THERMOCOUPLE PRACTICE	11
2.2.1. Terminating the thermocouple.....	11
2.2.2. External Reference Junction Techniques.....	13
2.3. THERMOCOUPLE INSTALLATION AND APPLICATION.....	14
2.3.1. Sheathed Thermocouples – Measuring Junctions.....	14
2.3.2. Connecting Thermocouples to Instruments	15
2.3.3. Guide to Wire and Cable Insulation and Coverings	17
2.3.4. Performance considerations when Connecting Thermocouples	17
2.4. DIFFERENT THERMOCOUPLE TYPES	19
2.5. THERMOCOUPLE CONSTRUCTION	21
2.6. ACCURACY AND RESPONSE.....	22
2.6.1. High Accuracy Thermocouple Measurement	22
2.6.2. Thermocouple Response Times.....	22
2.6.3. Immersion Length	23
2.6.4. Surface Temperature Measurement	24
3. RESISTANCE THERMOMETER THEORY AND PRACTICE	25
3.1. BASIC THEORY.....	25
3.2. ADOPTION OF Pt100 THERMOMETERS	27
3.3. RESISTANCE THERMOMETER PRACTICE	27
3.3.1. Terminating the Resistance Thermometer.....	27
3.3.2. Transmitters.....	30
3.4. RESISTANCE THERMOMETER INSTALLATION AND APPLICATION	30
3.4.1. Sheathed Resistance Thermometers – Pt100 Sensing Resistors.	30
3.4.2. Connecting Resistance Thermometers to Instruments	32
3.4.3. Guide to Cable Insulation and Coverings.....	33
3.4.4. Performance Considerations when Using Resistance Thermometers	33
3.4.5. Surface Temperature Measurement	35
3.4.6. High Accuracy Measurement.....	35

4. NTC THERMISTOR & INFRARED (NON-CONTACT) SENSORS.....	37
4.1. RESISTANCE / TEMPERATURE CHARACTERISTICS OF NTC THERMISTORS	37
4.1.1. Electrical Resistivity.....	38
4.1.2. Self-heating.....	39
4.2. INFRARED TEMPERATURE MEASUREMENT	39
4.2.1. Principles of Infrared Sensing.....	39
4.2.2. Methods of Measurement.....	39
5. SHEATH MATERIALS, THERMOWELLS, FITTINGS AND TERMINATIONS	41
5.1. CONSTRUCTION OF INDUSTRIAL TEMPERATURE PROBES.....	41
5.2. TERMINAL HEADS.....	42
5.3. SHEATH MATERIALS.....	43
5.3.1. Thermocouple Sheath Materials – Application Guide.....	43
5.3.2. Metallic and Non-metallic sheath materials	45
5.4. THERMOWELLS.....	46
5.5. FITTINGS.....	49
5.6. INTERCONNECTIONS.....	50
6. TEMPERATURE CALIBRATION	53
6.1. CERTIFICATION	54
6.2. THERMAL TEMPERATURE CALIBRATION	54
6.2.1. Equipment Required for a Calibration System.....	54
6.2.2. Fixed Points.....	57
6.2.3. Electrical Calibration – Simulators and Sources	58
7. TRANSMITTERS AND INSTRUMENTATION.....	59
7.1. SENSOR CONSIDERATIONS WITH INSTRUMENTATION	60
7.2. TRANSMITTERS AND SIGNAL CONDITIONING.....	61
7.3. INSTRUMENTATION & DATA COMMUNICATIONS & EMC	62
7.3.1. Temperature Measurement & Control	62
7.3.2. Data Acquisition & Logging.....	66
7.3.3. Data Communications & Analogue retransmission	67
7.3.4. Electro-magnetic compatibility (EMC).....	68
8. TEMPERATURE CONTROL	69
8.1. CONTROL LOOPS EXPLAINED	69
8.2. PID EXPLAINED	70

8.3.	OPTIMISING CONTROL TERMS (TUNING).....	74
8.4.	CONTROL OUTPUTS & ALARMS	75
9.	REFERENCE SECTION	77
9.1.	THERMOCOUPLE THERMOMETRY	77
9.1.1.	Thermocouple Accuracies IEC 584-2:1982	77
9.1.2.	Base Metal Extension and Compensating Wires and Cable Types and tolerances IEC 584-3:1989	78
9.1.3.	Wire and Cable Data	80
	Colour Codes IEC 584-3:1989 (inside back cover)	
9.2.	PLATINUM RESISTANCE THERMOMETRY.....	83
9.2.1.	Tolerances for Pt100 Thermometers to IEC 751:1983	83
9.2.2.	Connection Configurations and Termination Colour Codes IEC 751:1983	83
9.3.	THERMOCOUPLE AND Pt100 CHARACTERISTICS	84
9.3.1.	Pt100 Characteristics IEC 751:1983.....	84
9.3.2.	Thermocouple Characteristics IEC 584-1:1995	86
9.4.	GENERAL THERMOMETRY DATA AND OTHER REFERENCE INFORMATION	109
9.4.1.	Temperature Conversion Table °C / °F	109
9.4.2.	Fixed Temperature Points	110
9.4.3.	International Temperature Scale ITS-90.....	110
9.4.4.	Grades of Protection for Enclosures.....	111
9.4.5.	Problem Solving in Temperature Measurement & Control Using Thermocouples or Resistance Thermometers	113
9.4.6.	International and National Standard Specifications	114
10.	GLOSSARY OF TERMS	117
10.1	Abbreviations and Acronyms for Standards & Standard Bodies	117
10.2	Calibration.....	117
10.3	Control	118
10.4	Instrumentation – General.....	119
10.5	Thermometry – General	122
11.	ACKNOWLEDGEMENTS and REFERENCES	127
12.	FREQUENTLY ASKED QUESTIONS	128
13.	INDEX.....	133

1. TEMPERATURE MEASUREMENT USING ELECTRICAL TECHNIQUES

Thermocouples Resistance Thermometers and Thermistors are in effect electrical temperature transducers and not direct-indicating thermometers such as mercury-in-glass devices.

In the majority of industrial and laboratory processes, the measurement point is usually remote from the indicating or controlling instrument. This may be due to necessity (e.g. an adverse environment) or convenience (e.g. centralised data acquisition). Devices are required which convert temperature into another form of signal, usually electrical and most commonly thermocouples, resistance thermometers and thermistors.

Alternative indirect techniques for sensing and measuring temperature include optical pyrometry, other non-contact (infra red), fibre-optic and quartz oscillation systems.

The use of thermocouples, resistance thermometers and thermistors requires some form of physical contact with the medium. Such contact can be immersion or surface depending on the sensor construction and the application.

THERMOCOUPLES RESISTANCE THERMOMETERS AND THERMISTORS

Thermocouples essentially comprise a thermoelement (a junction of two specified dissimilar metals) and an appropriate two wire extension lead. A thermocouple operates on the basis of the junction located in the process producing a small voltage which increases with temperature. It does so on a reasonably stable and repeatable basis.

Resistance Thermometers utilise a precision resistor, the Ohms value of which increases with temperature (in the case of a positive temperature coefficient). Such variations are very stable and precisely repeatable.

Thermistors are an alternative group of temperature sensors which display a large value of temperature coefficient of resistance (usually negative, sometimes positive). They provide high sensitivity over a limited range

In practical terms, the alternative types of assembly utilise similar (in some case identical) construction but must be used in different ways depending on the application.

Comparison of Sensor Types

	Platinum Resistance Thermometer	Thermocouple	Thermistor
Sensor	Platinum-wire wound or flat-film resistor	Thermoelement, two dissimilar metals/ alloys	Ceramic (metal oxides)
Accuracy (typical values)	0.1 to 1.0°C	0.5 to 5.0°C	0.1 to 1.5°C
Long term Stability	Excellent	Variable, Prone to ageing	Good
Temperature range	-200 to 650°C	-200 to 1750°C	-100 to 300°C
Thermal response	Wirewound – slow Film – faster 1-50 secs typical	Sheathed – slow Exposed tip – fast 0.1 to 10 secs typical	generally fast 0.05 to 2.5 secs typical
Excitation	Constant current required	None	None
Characteristic	PTC resistance	Thermovoltage	NTC resistance (some are PTC)
Linearity	Fairly linear	Most types non-linear	Exponential
Lead resistance effect	3 & 4 wire – low 2 wire – high	Short cable runs satisfactory	Low
Electrical “pick-up”	Rarely susceptible	susceptible	Not susceptible
Interface	Bridge 2,3 or 4 wire	Potentiometric input. Cold junction compensation required	2 wire resistance
Vibration effects/ shock	wirewound – not suitable Film – good	Mineral insulated types suitable	Suitable
Output/ characteristic	approx. 0.4 Ω/°C	From 10μV/°C to 40μV/°C depending on type	-4% / °C
Extension Leads	Copper	Compensating cable	Copper
Cost	Wirewound – more expensive Film – cheaper	Relatively low cost	Inexpensive to moderate

Comments and values shown in this chart are generalised and nominal. They are not intended to be definitive but are stated for general guidance. The information given shows average application experience, but some of the considerations can be modified by special design or selection.

These alternative temperature sensors are explained in depth in chapters 2 ,3 and 4.

2. THERMOCOUPLE THEORY AND PRACTICE

2.1. BASIC THEORY

In 1821 a German physicist named Seebeck discovered the thermoelectric effect which forms the basis of modern thermocouple technology. He observed that an electric current flows in a closed circuit of two dissimilar metals if their two junctions are at different temperatures. The thermoelectric voltage produced depends on the metals used and on the temperature relationship between the junctions. If the same temperature exists at the two junctions, the voltages produced at each junction cancel each other out and no current flows in the circuit. With different temperatures at each junction, different voltages are produced and current flows in the circuit. A thermocouple can therefore only measure temperature differences between the two junctions, a fact which dictates how a practical thermocouple can be utilised.

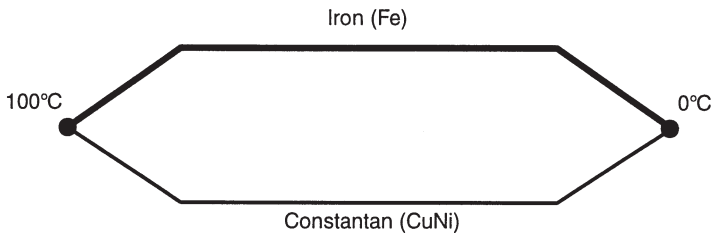

Fig 1: Thermoelement Circuit

It is important to designate each of the junctions **for practical purposes**; the **measuring junction** (often referred to as the “hot” junction) is that which is exposed to measured temperature. **The reference junction** is the other junction which is kept at a known temperature; this is often referred to as the “cold” junction. The term thermocouple refers to the complete system for producing thermal voltages and generally implies an actual assembly (i.e. a sheathed device with extension leads or terminal block.) The two conductors and associated measuring junction constitute a **thermoelement** and the individual conductors are identified as the positive or negative **leg**.

*Developments in theoretical aspects of thermoelectricity under the influence of solid-state physics has resulted in a rather different explanation of thermocouple activity. This is that the thermoelectric voltage is generated in the thermocouple wires **only in the temperature gradient existing between the “hot” and “cold” junctions** and not in the junctions themselves. Whilst this is a fundamental conceptual difference to established theory the way in which thermocouples are currently used is generally successful in practical terms. However, this explanation of thermocouple behaviour must be borne in mind when calibrating the sensor or indeed when using them for relatively high precision thermometry.*

Thermoelectric voltages are very small and at best attain a few tens of microvolts per degree Centigrade. In consequence, practical thermocouples are mainly used at elevated temperatures, above say 100°C and at depressed temperatures, below -50°C; however with appropriate measuring instruments they can be used at any value within their operational range. In some applications, the reference junction may be held at some temperature other than 0°C, for example in liquid gas or a heated enclosure; in any event, the measured “output” will correspond to the difference temperature between the two junctions (fig 2)

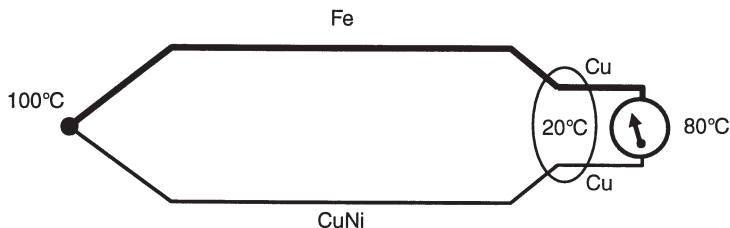

Fig 2: Thermoelement with Connecting Wires

Note Thermocouples are **always** formed when two different metals are connected together. For example, when the thermoelement conductors are joined to copper cable or terminals, thermal voltages can be generated at the transition (see fig. 2). In this case, the second junction can be taken as located at the connection point (assuming the two connections to be thermally common). The temperature of this connection point (**terminal temperature**) if known, allows computation of the temperature at the measuring junction. The thermal voltage resulting from the terminal temperature is added to the measured voltage and their sum corresponds to the thermal voltage against a 0°C reference.

*e.g. If the measuring junction is at 300°C and the terminal temperature is 25°C, the measured thermal voltage for the type K thermoelement (Nickel-Chromium v Nickel-Aluminium) is 11.18mV. This corresponds to 275°C **difference** temperature. A positive correction of 25°C refers the temperature to 0°C; 300°C is thus indicated.*

2.2. THERMOCOUPLE PRACTICE

2.2.1. Terminating the Thermocouple

A practical industrial or laboratory thermocouple consists of only a single (measuring) junction; the reference is always the terminal temperature. If the terminal temperature is other than controlled and stable, procedures are necessary to deal with the situation. Possible measures are:-

- Measure the terminal temperature accurately and compensate accordingly in calculating the measured value.

- b) Locate the terminals in a thermally controlled enclosure
- c) Terminate not in copper cable but use compensating or actual thermocouple wire to extend the sensor termination to the associated instrumentation (compensating cable uses low cost alloys which have similar thermoelectric properties to the actual thermoelement). On this basis, there is no thermal voltage at the thermocouples termination. The transition to copper then occurs only at the instrument terminals where the ambient temperature can be measured by the instrument; the reference junction can then be compensated for electronically.

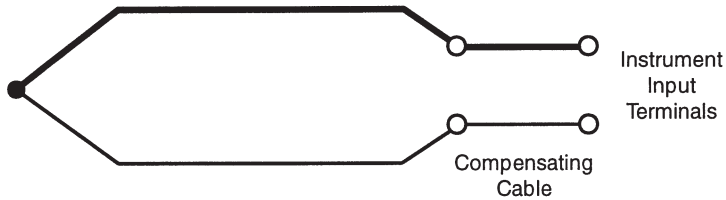

Fig 3: Thermoelement with Compensating Cable

Note: It is essential to use only compensating or specific extension cables (these have the correct thermoelectric properties) appropriate to the thermocouple otherwise an additional thermocouple is formed at the connection point. The reference junction is formed where the compensating or extension cable is connected to a different material. The cable used must not be extended with copper or with compensating cable of a different type.

- d) Use a **temperature transmitter** at the termination point. This is effectively bringing instrumentation close to the sensor where electronic reference junction techniques can be utilised. However, this technique is convenient and often used on plant; a transmitter produces an amplified "corrected" signal which can be sent to remote instruments via copper cable of any length.

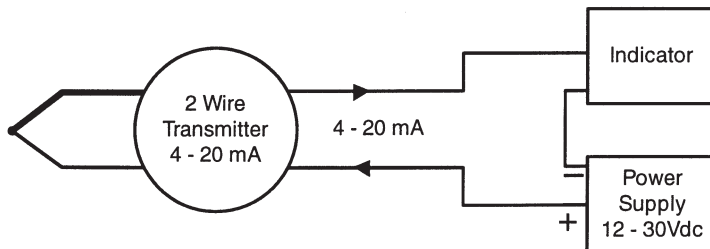

Fig 4: Temperature Transmitter – 2 Wire

2.2.2. External Reference Junction Techniques

Reference junction technology is usually considered as one of the main problems of any thermocouple installation. Individual instruments with thermocouples are generally provided with automatic 'cjc' (cold junction compensation). These devices sense the temperature at the point where the thermocouple is joined to the copper wiring of the instrument, and apply a corrective signal. Scanning devices such as data loggers are increasingly using this method.

Where optimum accuracy is needed and to accommodate multi-thermocouple installations, larger reference units are used. These are claimed to have an accuracy of $\pm 0.1^\circ\text{C}$ or better, and allow the cables to the instrumentation to be run in copper, with no further temperature corrective device needed. The reference units are contained basically under three techniques.

- a) **The Ice Point.** This is a method of feeding the emf from the thermocouple to the measuring instrumentation via the ice-point reference which is usually operated under one of two methods, the bellows type and the temperature sensor type.

The bellows type utilises the precise volumetric increase which occurs when a known quantity of ultra pure water changes state from liquid to solid. A precision cylinder actuates expansion bellows which control power to a thermoelectric cooling device.

The temperature sensor switch type uses a metal block of high thermal conductance and mass, which is thermally insulated from ambient temperatures. The block temperature is lowered to 0°C by a cooling element, and maintained there by a temperature sensing device. A feature of this unit is its quick "pull down" time to 0°C . Special thermometers are obtainable for the checking of 0°C reference units, and alarm circuits that detect any movement from the zero position can be fitted. For calibration purposes the triple point cell which shows the equilibrium temperature between liquid water, ice and water vapour, and can be reproduced to extreme accuracy, is used.

The traditional Dewar flask filled with melting ice should be used with caution. Unless care and expertise are used in the making up and maintenance of the flask, comparatively large errors can result. When available a 0°C reference unit should be used.

- b) **The "Hot Box".** Thermocouples are calibrated in terms of emf generated by the measuring junctions relative to the reference junction at 0°C , referencing at another temperature therefore does present problems. However, the ability of the hot box to work at very high ambient temperatures, plus a good reliability factor has led to an increase in its usage.

The unit can consist of a solid state aluminium block thermally insulated in which the reference junctions are embedded. The block temperature is controlled by a closed loop electronic system, and a heater is used as a booster when initially switching on. This booster drops out before the reference temperature, usually between 40°C and 65°C , is reached.

- c) **Isothermal Systems.** The thermocouple junctions being referenced are contained in a block which is heavily thermally insulated. The junctions are allowed to follow the mean ambient temperature, which varies slowly. This variation is accurately sensed by electronic means, and signal is produced for the associated instrumentation. The high reliability factor of this method has favoured its use for long term monitoring.

2.3. THERMOCOUPLE INSTALLATION AND APPLICATION

2.3.1. Sheathed Thermocouples – Measuring Junctions

Many alternative sheath materials are used to protect thermoelements and some examples are indicated in a separate chapter. Additionally, three alternative tip configurations are usually offered:

- a) **An exposed (measuring) junction** is recommended for the measurement of flowing or static non-corrosive gas temperature when the greatest sensitivity and quickest response is required.



Fig 5: Exposed Junction

- b) **An insulated junction** is more suitable for corrosive media although the thermal response is slower. In some applications where more than one thermocouple connects to the associated instrumentation, insulation may be essential to avoid spurious signals occurring in the measuring circuits.

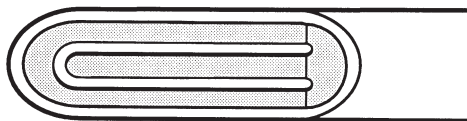

Fig 6: Insulated Junction

- c) **An earthed (grounded) junction** is also suitable for corrosive media and for high pressure applications. It provides faster response than the insulated junction and protection not afforded by the exposed junction.

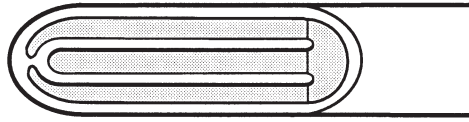

Fig 7: Earthed Junction

2.3.2 Connecting Thermocouples to Instruments

In industrial installations where the measuring and control instruments are located remotely from the thermocouples, compensating cable can be used between the sensor and instrument to reduce cabling costs.

Compensating cable resembles the thermoelectric characteristic of the relevant thermocouple over a limited ambient temperature range, 0° to 80°C typically. Since these cables are made from low cost materials, cost savings can be achieved on plant installations compared with running true thermocouple extension cable.

Extension cable (true thermocouple material) should be used for maximum accuracy.

Installation Notes:

- a) Always observe colour codes and polarity of connections for each type of thermocouple. If the current lead is used but crossed at both ends, the associated instrument will show an error equal to **twice** the temperature difference between the thermocouple termination and the instrument ambient.
- b) Avoid introducing "different" metals into the cabling, preferably use compensating colour coded connectors for the greatest accuracy, reliability and convenience of installation.
- c) Avoid subjecting compensating cable to high temperatures to avoid inaccuracies. Extension cable is superior in this respect.
- d) Do not form thermo-junctions using compensating cable; only extension cable is valid for this purpose.
- e) Use screened or braided cable connected to ground in any installation where ac pick-up or relay contact interference is likely. "Twisted pair" construction is useful in such situations.

- f) For very long cable runs, ensure that cable resistance can be tolerated by the instrumentation without resulting in measurement errors. Modern electronic instruments usually accept up to 100 Ohms or so; they will usually tolerate higher lead resistance but some error will result. Refer to relevant instrument specifications for full details.
- g) Cabling is usually available with many different types of insulation material and outer covering to suit different applications. Choose carefully in consideration of ambient temperature, the presence of moisture or water and the need for abrasion resistance.
- h) If errors or indicator anomalies occur, be sure to check the thermocouple, the cable, interconnections **and** the instrument. Many such problems are due to incorrect wiring or instrument calibration error rather than the sensor.

Interchangeability is facilitated by the use of **plug and socket interconnections**. Special connectors are available for this purpose and thermocouple alloys or compensating materials are used for the pins and receptacles to avoid spurious thermal voltages. Such connectors are usually colour coded to indicate the relevant thermocouple type and are available as "standard" size with round pins or "miniature" size with flat pins.

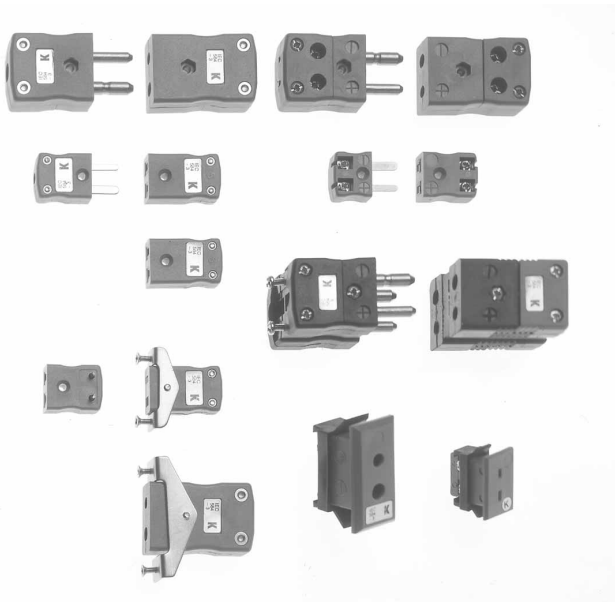

Fig 8: Plug and Socket Interconnections

2.3.3. Guide to Wire and Cable Insulation and Coverings

For maximum accuracy extension cables should be used and terminals and connectors should be of thermocouple materials to maintain continuity.

Which insulation Material?	usable temperature range	Application Notes
PVC	-10°C to 105°C	Good general purpose insulation for "light" environments. Waterproof and very flexible.
PFA (extruded)	-75°C to 250°C	Resistant to oils, acids other adverse agents and fluids. Good mechanical strength and flexibility. PTFE better for steam/elevated pressure environments
PTFE (taped & wrapped)	-75°C to 250/300°C	Resistant to oils, acids other adverse agents and fluids. Good mechanical strength and flexibility.
Glassfibre (varnished)	-60°C to 350/400°C	Good temperature range but will not prevent ingress of fluids. Fairly flexible but does not provide good mechanical protection.
High temperature glass fibre	-60°C to 700°C	Will withstand temperature up to 700°C but will not prevent ingress of fluids. Fairly flexible, not good protection against physical disturbance.
Ceramic Fibre	0 to 1000°C	Will withstand high temperature, up to 1000°C. Will not protect against fluids or physical disturbance.
Glassfibre (varnished) stainless steel overbraid	-60°C to 350/400°C	Good resistance to physical disturbance and high temperature (up to 400°C). Will not prevent ingress of fluids.

Single or multi-strand?

The choice is mainly determined by the application (e.g.. termination considerations and internal diameter of associated sheath). Generally, single strand wires are used for hot junctions, and multi-strand or thicker single strand for extensions of the thermocouple. The greater the effective conductor diameter, the lower the value of thermocouple loop resistance, an important consideration with long cable runs.

2.3.4. Performance Considerations When Connecting Thermocouples

a) Length of cable runs and loop resistance.

The resistivity of extension and compensating cables varies according to the different conductor metals; the limit to cable lengths which can be accommodated by measuring instruments therefore depends on both the thermocouple type and instrument specifications. A general rule for electronic instruments is that up to 100 Ohms loop cable resistance (i.e. total of both legs) will not result in measurement errors.

The table of loop resistances shown in the reference chapter gives values for the popular types of thermocouple. One example is that of Type K extension cable which has a combined loop resistance of 4.5Ω/m with 7/0.2mm conductors; in this case, 20 to 25 ($100 \div 4.5$) metres is the maximum permissible cable run. The use of larger gauge wires will permit greater lengths of course.

b) Interference and Isolation.

With long runs, the cables may need to be screened and earthed at one end (at the instrument) to minimise noise pick-up (interference) on the measuring circuit.

Alternative types of screened cable construction are available and these include the use of copper or mylar screening. Twisted pair configurations are offered and these can incorporate screening as required.

With mineral-insulated cables the use of the sheath for screening may raise problems. In certain forms the measuring point is welded to the sheath in order to reduce the response time; the screen is then connected directly to the sensor input of the instrument and is therefore ineffective. In thermocouples where the measuring point is welded to the protection tube it may be necessary to take special precautions against interference since the sheath tube can in this case act as an aerial.

Even if the measuring point is not welded to the protection tube it is inadvisable to use the sheath of a mineral-insulated thermocouple as a screen. Since it consists of non-insulated material there is a possibility with electrically heated furnaces that it can carry currents between the furnace material and the earthing point. These may result in measurement errors.

Generally, thermocouples in electrical contact with the protection tube can easily suffer interference from external voltages through voltage pick-up. In addition, two such inputs form a current loop through which the two inputs are connected together. Since such current loops form a preferred path for the introduction of interference, thermocouples should under these conditions always be **isolated** from each other, i.e. the amplifier circuits must have no electrical connection to the remaining electronics. This is already provided on most instruments intended for connection to thermocouples.

Ceramic materials used for insulating the thermocouples inside the protection tube suffer a definite loss of insulation resistance above 800 to 1000°C. The effects described can therefore appear at high temperatures even in thermocouples where the measuring junction is not welded to the protection tube. Here again full isolation is strongly recommended.

With electrically heated furnaces in the high-temperature range it is also necessary to consider that the increased conductivity of the ceramic insulating materials may cause the supply voltage to leak into the thermocouple. Here again full isolation against supply and earth potential with an insulating voltage exceeding the peak voltage of the supply (heater voltage) is essential.

The isolation of the inputs becomes specially important when electrically heated furnaces are fitted with several thermocouples which are linked to one or several instruments.

c) Thermal Voltages and terminals.

The use of brass or copper terminals in the thermocouple circuit may or may not introduce thermal voltages depending on how they are used. Interposing one or two terminations in one or both legs is permissible **provided that the temperature on both sides of the termination is exactly the same.**

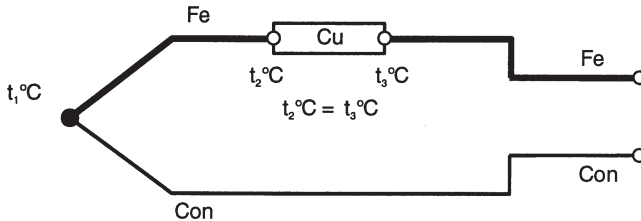

Fig 9: Using a Copper Terminal(s) in a Thermocouple Circuit

The thermal voltages produced at the junctions of Iron – Copper and Copper – Iron cancel each other at the same temperature because they are of opposite polarity, regardless of the actual temperature and of the material. This is only the case if the temperatures at both ends of the termination are the same.

With the usual two terminations, one for each core of the cable, the temperature of each can be different; it is vital though that the same temperature exists on both sides of a given termination.

Where a connection is made under circumstances of temperature variation; it is essential to use connectors free of thermal voltage effects; these are widely available.

2.4. DIFFERENT THERMOCOUPLE TYPES

The materials are made according to internationally accepted standards as laid down in IEC 584 1,2 which is based on the international Practical Temperature scale ITS 90. Operating temperature maxima are dependent on the conductor thickness of the thermoelements. The thermocouple types can be subdivided in 2 groups, **base metal and rare (noble) metal:**

-200°C up to 1200°C – These thermocouples use base metals

Type K – Chromel-Alumel

The best known and dominant thermocouple belonging to the group chromium-nickel aluminium is type K. Its temperature range is extended (-200 up to 1100°C). Its e.m.f./ temperature curve is reasonably linear and its sensitivity is 41µV/°C

Type J – Iron-Constantan

Though in thermometry the conventional type J is still popular it has less importance in Mineral Insulated form because of its limited temperature range, -200°C to +750°C. Type J is mainly still in use based on the widespread applications of old instruments calibrated for this type. Their sensitivity rises to 55 μ V/°C.

Type E – Chromel-Constantan

Due to its high sensitivity (68 μ V/°C) Chromel-Constantan is mainly used in the cryogenic low temperature range (-200 up to +900°C). The fact that it is non magnetic could be a further advantage in some special applications.

Type N – Nicrosil-Nisil

This thermocouple has very good thermoelectric stability, which is superior to other base metal thermocouples and has excellent resistance to high temperature oxidation.

The Nicrosil-Nisil thermocouple is ideally suited for accurate measurements in air up to 1200°C. In vacuum or controlled atmosphere, it can withstand temperatures in excess of 1200°C. Its sensitivity of 39 μ V/°C at 900°C is slightly lower than type K (41 μ V/°C). Interchangeability tolerances are the same as for type K.

Type T – Copper-Constantan

This thermocouple is used less frequently. Its temperature range is limited to -200°C up to +350°C. It is however very useful in food, environmental and refrigeration applications. Tolerance class is superior to other base metal types and close tolerance versions are readily obtainable. The e.m.f./temperature curve is quite non-linear especially around 0°C and sensitivity is 42 μ V/°C.

0°C up to +1600°C – Platinum-Rhodium (Noble metal) Thermocouples

Type S – Platinum rhodium 10% Rh-Platinum

They are normally used in oxidising atmosphere up to 1600°C. Their sensitivity is between 6 and 12 μ V/°C.

Type R – Platinum rhodium 13% Rh-Platinum

Similar version to type S with a sensitivity between 6 and 14 μ V/°C.

Type B – Platinum rhodium 30% Rh-Platinum rhodium 6% Rh

It allows measurements up to 1700°C. Very stable thermocouple but less sensitive in the lower range. (Output is negligible at room temperature).

Historically these thermocouples have been the basis of high temperature in spite of their high cost and their low thermoelectric power. Until the launching of the Nicrosil-Nisil thermocouples, type N, they remained the sole option for good thermoelectric stability.

Additionally, there are specialised thermocouple types which are not described here; these include Tungsten Rhenium types, Pallaplat, Nickel Molybdenum and other Platinum Rhodium alloys.

2.5. THERMOCOUPLE CONSTRUCTION

Many alternative configurations exist for thermocouple assemblies; basically two general types of construction describe most industrial thermocouples – **fabricated** and **mineral insulated**.

Fabricated Thermocouples are assembled using insulated thermocouple wire, sheathing (usually stainless steel) and some form of termination (extension lead, connecting head or connector for example)



Fig 10: Fabricated Thermocouple
Insulated, Twisted Pair Thermocouple inside Stainless Steel Sheath.
Measuring junction earthed in this example.

Mineral Insulated Thermocouples consist of thermocouple wire embedded in a densely packed refractory oxide powder insulant all enclosed in a seamless, drawn metal sheath (usually stainless steel).

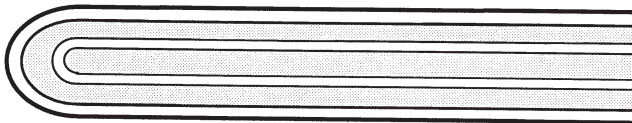

Fig 11: Mineral Insulated Thermocouple
Thermocouple wire insulated by compressed mineral oxide powder..
Insulated measuring junction shown in this example.

Effectively, the thermoelement, insulation and sheath are combined as a flexible cable which is available in different diameters, usually from 0.5mm to 8mm.

At one end, the cores and sheath are welded and form a “hot” junction. At the other end, the thermocouple is connected to a “transition” of extension wires, connecting head or connector.

Advantages of Mineral Insulated Thermocouples are:

- a) Small overall dimension and high flexibility which enable temperature measurement in locations with poor accessibility.
- b) Good mechanical strength
- c) Protection of the thermoelement wires against oxidation, corrosion and contamination.
- d) Fast thermal response

The mineral oxides used for insulation are highly hygroscopic and open ended cable must be effectively sealed (usually with epoxy resins) to prevent moisture take-up. A carefully prepared mineral insulated thermocouple will normally have a high value of insulation resistance (many hundreds of MOhms).

2.6. ACCURACY AND RESPONSE

2.6.1. High Accuracy Thermocouple Measurement

With thermocouple tolerances quoted at say $\pm 2.5^\circ\text{C}$ plus other variations it would appear a poor case could be made out for high accuracy thermocouple measurement, for example in research and high industrial technology. The key to accuracy in this field lies in the careful selection of methods and materials, and the heat treatment and calibration of the thermocouples. While application conditions do alter techniques, the following factors are suggested for consideration.

1. Obtain thermocouples with insulated measuring junctions.
2. Specify “same melts” for large installations.
3. Thermocouple reference junctions should be monitored in a reference unit with an accuracy of $\pm 0.1^\circ\text{C}$ or better.
4. Great care to be taken in running thermocouple circuitry against “pick-up” etc. with the minimum number of joins in the wiring.
5. Heat treat thermocouples to their most stable condition.
6. Calibrate thermocouples.

2.6.2. Thermocouple Response Times

The response time for a thermocouple is usually defined as the time taken for the thermal voltage (output) to reach 63% of maximum for the step change temperature in question. It is dependent on several parameters including the thermocouple dimension, construction, tip configuration and the nature of the medium in which the sensor is located. If the thermocouple is plunged into a medium with a high thermal capacity and heat transfer is rapid, the effective response time will be practically the same as for the thermocouple itself

(the intrinsic response time). However, if the thermal properties of the medium are poor (e.g. still air) the response time can be 100 times greater.

Sheath Outside Diameter	Types of Measuring Junction	Response Time – Seconds					
		Tip Temperature °C					
		100	250	350	430	700	850
6.0mm	insulated	3.2	4.0	4.7	5.0	6.4	16.0
6.0mm	earthed	1.6	2.0	2.3	2.5	3.15	8.0
3.0mm	insulated	1.0	1.1	1.25	1.4	1.6	4.5
3.0mm	earthed	0.4	0.46	0.5	0.56	0.65	1.8
1.5mm	insulated	0.25	0.37	0.43	0.50	0.72	1.0
1.5mm	earthed	0.14	0.17	0.185	0.195	0.22	0.8
1.0mm	insulated	0.16	0.18	0.19	0.21	0.24	0.73
1.0mm	earthed	0.07	0.09	0.11	0.12	0.16	0.6

Values shown are for a closed end sheath.

For exposed measuring junctions, divide the values shown by 10.

Fig 12: Table of Typical Thermocouple Response Times. Mineral insulated construction, closed end sheath.

Thermocouples with grounded junctions display response times some 20 to 30% faster than those with insulated junctions. Very good sensitivity is provided by fine gauge unsheathed thermocouples. With conductor diameter in the range 0.025mm to 0.81mm, response times in the region of 0.05 to 0.40 seconds can be realised.

2.6.3. Immersion Length

Thermocouple assemblies are “tip” sensing devices which lends them to both surface and immersion applications depending on their construction. However, immersion types must be used carefully to avoid errors due to stem conduction; this is heat flow to or from the sheath and into or away from the process which can result in a high or low reading respectively. A general rule is to immerse into the medium to a minimum of 4 times the outside diameter of the sheath; no quantitative data applies but care must be exercised in order to obtain meaningful results (e.g. have regard for furnace wall thickness and such like).

The ideal immersion depth can be achieved in practice by moving the probe into or out of the process medium incrementally; with each adjustment, note any apparent change in indicated temperature. The correct depth will result in no change in indicated temperature.

2.6.4. Surface Temperature Measurement

Although thermocouple assemblies are primarily tip sensing devices, the use of protection tubes (sheaths) renders surface sensing impractical. Physically, the probe does not lend itself to surface presentation and stem conduction would cause reading errors. If a thermocouple is to be used reliably for surface sensing, it must be in either exposed, welded junction form with very small thermal mass or be housed in a construction which permits true surface contact whilst attaching to the surface. Locating a thermocouple on a surface can be achieved in various ways including the use of an adhesive patch, a washer and stud, a magnet for ferrous metals and pipe clips. Examples of surface sensing thermocouples are shown below:

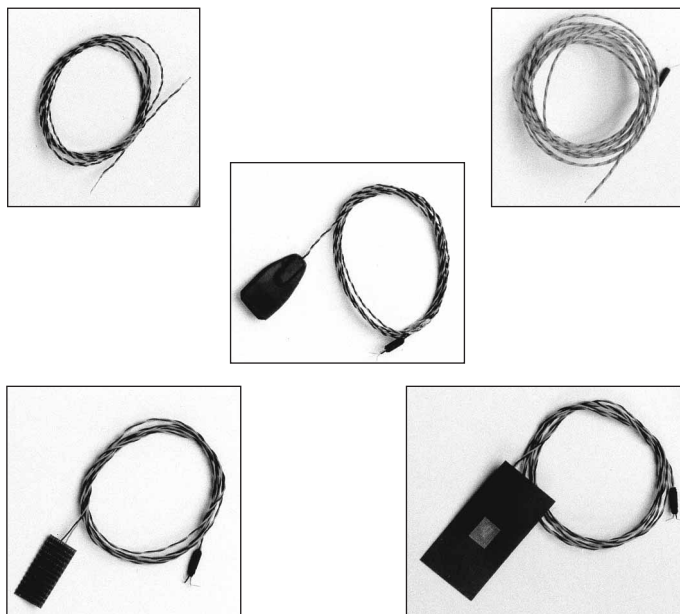

Fig 13: Thermocouples for Surface Temperature Sensing

If it is possible to provide lagging (thermal insulation) around the sensor assembly, accuracy will be improved. Thermocouples are ideal for such applications since their measuring junctions have a very small thermal mass and are physically small.

3. RESISTANCE THERMOMETER THEORY AND PRACTICE

3.1. BASIC THEORY

The electrical conductivity of a metal depends on the movement of electrons through its crystal lattice. Due to thermal excitation, the electrical resistance of a conductor varies according to its temperature and this forms the basic principles of resistance thermometry. The effect is most commonly exhibited as an increase in resistance with increasing temperature, a **positive temperature coefficient of resistance**.

When utilising this effect for temperature measurement, a large value of temperature coefficient (the greatest possible change of resistance with temperature) is ideal; however, stability of the characteristic over the short and long term is vital if practical use is to be made of the conductor in question. The relationship between the temperature and the electrical resistance is usually non-linear and described by a higher order polynomial:

$$R(t) = R_0 (1 + A:t + B:t^2 + C:t^3 + \dots)$$

where R_0 is the nominal resistance at a specified temperature. The number of higher order terms considered is a function of the required accuracy of measurement. The coefficients A, B and C etc. depend on the conductor material and basically define the temperature -resistance relationship.

Materials most commonly utilised for resistance thermometers are Platinum, Copper and Nickel. However, Platinum is the most dominant material internationally

Platinum Sensing Resistors

Platinum sensing resistors are available with alternative R_0 values, for example 10, 25 and 100 Ohms. A working form of resistance thermometer sensor is defined in IEC and DIN specifications and this forms the basis of most industrial and laboratory electrical thermometers. The **platinum sensing resistor**, Pt100 to IEC 60751 is dominant in Europe and in many other parts of the world. Its advantages include chemical stability, relative ease of manufacture, the availability of wire in a highly pure form and excellent reproducibility of its electrical characteristic. The result is a truly interchangeable sensing resistor which is widely commercially available at a reasonable cost.

This specification includes the standard variation of resistance with temperature, the nominal value with the corresponding reference temperature, and the permitted tolerances. The specified temperature range extends from -200 to 961.78°C. The series of reference values is split into two parts: -200 to 0°C and 0 to 961.78°C.

The first temperature range is covered by a third-order polynomial

$$R(t) = R_0(1 + A.t + B.t^2 + C. [t - 100^\circ\text{C}] .t^3)$$

For the range 0 to 850°C there is a second-order polynomial

$$R(t) = R_0(1 + A.t + B.t^2)$$

The coefficients are as follows:

$$A = 3.9083 \times 10^{-3} \cdot ^\circ\text{C}^{-1}$$

$$B = -5.775 \times 10^{-7} \cdot ^\circ\text{C}^{-2}$$

$$C = -4.183 \times 10^{-12} \cdot ^\circ\text{C}^{-4}$$

The value R_0 is referred to as **nominal value** or **nominal resistance** and is the resistance at 0°C. According to IEC 751 the nominal value is defined as 100.00 Ohm, and this is referred to as a **Pt100** resistor. Multiples of this value are also used; resistance sensors of 500 and 1000 Ohm are available to provide higher sensitivity, i.e. a larger change of resistance with temperature.

The resistance changes are approximately:

0.4 $\Omega/^\circ\text{C}$ for the Pt100

2.0 $\Omega/^\circ\text{C}$ for the Pt500

4.0 $\Omega/^\circ\text{C}$ for the Pt 1000

An additional parameter defined by the standard specification is the mean temperature coefficient between 0 and 100°C. It represents the mean resistance change referred to the nominal resistance at 0°C:

$$\alpha = \frac{R_{100} - R_0}{R_0 \times 100^\circ\text{C}} = 3.850 \times 10^{-3} \text{ } ^\circ\text{C}^{-1}$$

Note: For exact calculation use $\alpha = 0.00385055^\circ\text{C}^{-1}$

R_{100} is the resistance at 100°C, R_0 at 0°C. The resistance change over the range 0°C to 100°C is referred to as the **Fundamental Interval**.

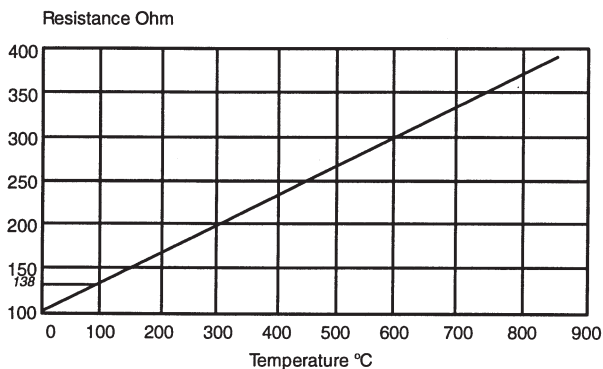

Fig 14: Resistance/Temperature Characteristics of Pt100

The very high accuracy demanded of primary standard resistance thermometers requires the use of a more pure form of platinum for the sensing resistor. This results in different R_0 and alpha values. Conversely, the platinum used for Pt100 versions is “doped” to achieve the required R_0 and Alpha values.

3.2. ADOPTION OF Pt100 THERMOMETERS

The practical range of Pt100 based thermometers extends from -200°C to 650°C although special versions are available from up to 962°C. Their use has in part taken over from thermocouples in many applications for a variety of reasons:

- a) Installation is simplified since special cabling and cold junction considerations are not relevant. Similarly, instrumentation considerations are less complex in terms of input configuration and enhanced stability.
- b) Instrumentation developments have resulted in high accuracy, high resolution and high stability performance from lower cost indicators and controllers; such accuracy can be better exploited by the use of superior temperature sensors.
- c) The availability of a growing range of sensing resistor configurations has greatly expanded the scope of applications; such configurations include miniature, flat-film fast response versions in addition to the established wirewound types with alternative tolerance bands.

The usable maximum temperature of the sensing resistor is dependent on the type of sheath material used to provide protection. Those using stainless steel should not exceed 500°C because of contamination effects. Nickel and Quartz are alternative choices allowing higher operating temperatures.

Refer to section 1 of this handbook for comparisons between Resistance Thermometers and Thermocouples.

3.3. RESISTANCE THERMOMETER PRACTICE

3.3.1. Terminating the Resistance Thermometer

Fundamentally, every sensing resistor is a two wire device. When terminating the resistor with extension wires, a decision must be made as to whether a 2,3 or 4 wire arrangement is required for measurement purposes.

In the sensing resistor, the electrical resistance varies with temperature. Temperature is measured indirectly by reading the voltage drop across the sensing resistor in the presence of a constant current flowing through it using Ohm's Law: $V = R.I$

The measuring current should be as small as possible to minimise sensor heating; a maximum of around 1mA is regarded as acceptable for practical purposes. This would produce a 0.1V drop in a Pt100 sensing resistor at 0°C; the voltage dropped which varies with temperature is then measured by the associated circuitry.

The interconnection between the Pt100 and the associated input circuit must be compatible with both and the use of 2,3 or 4 wires must be specified accordingly.

It is essential that in any resistance thermometer the resistance value of the external leadwires be taken into account, and if this value affects the required accuracy of the thermometer, its effect should be minimised.

This is usually accomplished by connecting the leadwires into the modified **WHEATSTONE BRIDGE** circuit in the measuring instrumentation. The leadwires can be 2,3 or 4 in number, often dependant upon the requirements of the instrumentation and/or the overall accuracy required. Two leads are adequate for some industrial applications, three leads compensating for lead resistance improves accuracy, and for the highest accuracy requirements four leads are required, in a current/voltage measuring mode. Typical bridge circuits for 2, 3 and 4 lead thermometers are shown below:

Fig 15: Practical Bridge Circuits for 2, 3 and 4 Wire Thermometers.

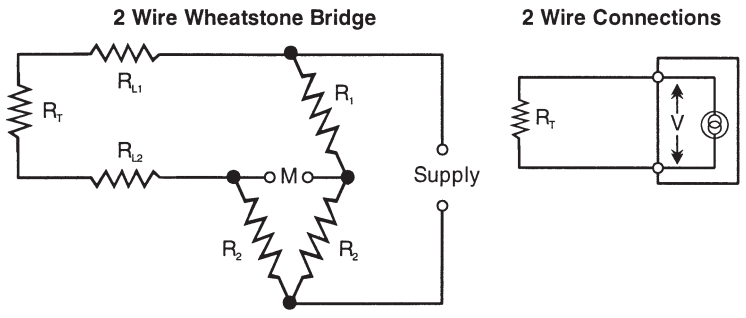

The meter reads $R_T + (R_{L1} + R_{L2})$. R_{L1} , R_{L2} are lead resistances.

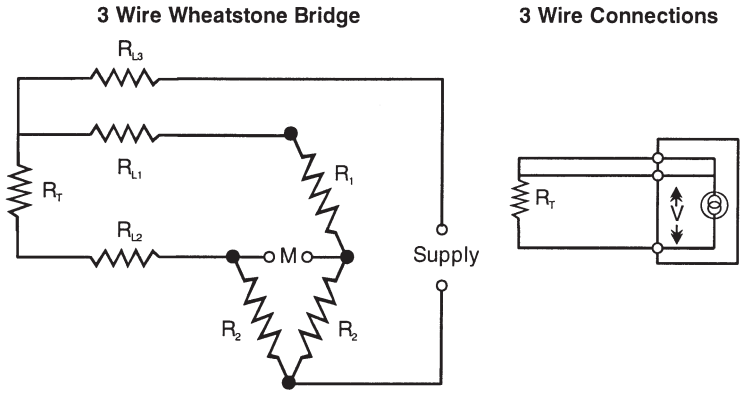

One lead resistance is included in each of the two arms of the bridge. The errors reduce to $R_{L1} - R_{L2}$.

4 Wire Compensated Wheatstone Bridge

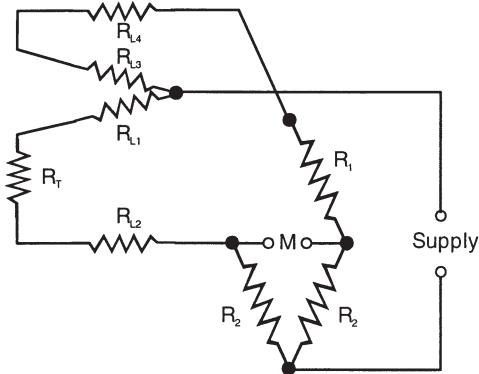

4 Wire Connections

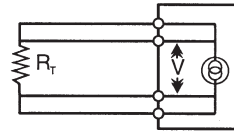

R_{L3} , R_{L4} appear in one arm of the bridge and R_{L1} , R_{L2} in the other.
Errors are $R_{L1} + R_{L2} - R_{L3} - R_{L4}$.

The connection between the thermometer assembly and the instrumentation is made with standard electrical cable with copper conductors in 2,3 or 4 core construction. The cabling introduces electrical resistance which is placed in series with the resistance thermometer. **The two resistances are therefore cumulative and could be interpreted as an increased temperature if the lead resistance is not allowed for.** The longer and/or the smaller the diameter of the cable, the greater the lead resistance will be and the measurement errors could be appreciable. In the case of a **2 wire connection**, little can be done about this problem and some measurement error will result according to the cabling and input circuit arrangement.

For this reason, **a 2 wire arrangement is not recommended.** If it is essential to use only 2 wires, ensure that the largest possible diameter of conductors is specified and that the length of cable is minimised to keep cable resistance to as low a value as possible.

The use of 3 wires, when dictated either by probe construction or by the input termination of the measuring instrument, will allow for a good level of lead resistance compensation. **However the compensation technique is based on the assumption that the resistance of all three leads is identical** and that they all reside at the same ambient temperature; this is not always the case. Cable manufacturers often specify a tolerance of up to $\pm 15\%$ in conductor resistance for each core making accurate compensation impossible. Additional errors may result from contact resistance when terminating each of the 3 wires. A 3 wire system can not therefore be relied upon for total accuracy.

Optimum accuracy is therefore achieved with a 4 wire configuration. The Pt100 measuring current is obtained through the supply. The voltage drop across the sensing resistor is picked off by the measurement wires. If the measurement circuit has a very high input impedance, lead resistance and connection contact resistances have negligible effect. The voltage drop thus obtained is independent of the connecting wire resistivity. In practice, the transition from the 2 wires of the Pt100 to the extension wires may not occur precisely at the element itself but may involve a short 2 wire extension for reasons of physical construction; such an arrangement can introduce some error but this is usually insignificant.

Note: The wiring configuration (2,3, or 4 wire) of the thermometer must be compatible with the input to the associated instrument.

3.3.2. Transmitters

The problems of the 2 or 3 wire configuration as described can be resolved in large part by using a 4-20mA transmitter. If the transmitter is located close to the Pt100, often in the terminal head of the thermometer, then the amplified “temperature” signal is transmitted to the remote instrumentation. Cable resistance effects are then not applicable other than those due to the relatively short leadwires between the sensor and transmitter.

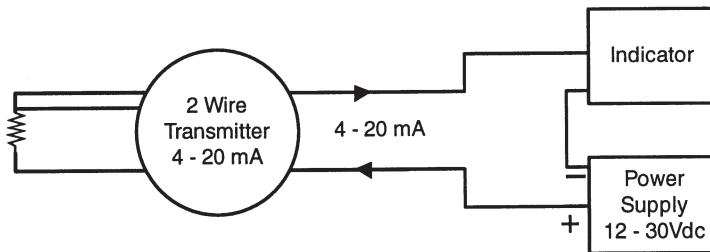

Fig 16: Temperature Transmitter – 2 Wire Loop. Input Pt100, 3 Wire

Most transmitters use a 3 wire input connection and therefore provide compensation for lead resistance.

3.4. RESISTANCE THERMOMETER INSTALLATION AND APPLICATION

3.4.1. Sheathed Resistance Thermometers – Pt100 Sensing Resistors

A variety of sheath materials is used to house and protect the alternative types of sensing resistors; sheath materials are described in a separate chapter.

The resistance element is produced in one of two forms, either wire-wound or metal film. Metal film resistors consist of a platinum layer on a ceramic substrate; the coil of a wire wound version is fused into ceramic or glass.

a) Wire – wound resistors.

The construction of the wire wound platinum detector uses a large proportion of manual labour, with a high degree of training and skill. The careful selection of all components is vital, as are good working conditions. Complete compatibility between metal, ceramic and glass when used, together with the connecting leads is essential, and most important, strain must be eliminated. Various methods of detector construction are employed to meet the requirements of differing applications. The unsupported “bird cage” construction is used for temperature standards, and the partially supported construction is used where a compromise is acceptable between primary standards and use in industrial applications. Other constructional methods include the totally supported construction which can normally withstand vibration levels to 100g, and the coated wire construction where the wire is covered with an insulating medium such as varnish. The maximum operating range of the latter method is limited by the wire coating to usually around 250°C.

Of the differing methods of construction described, the partially supported construction is the most suited for industrial applications where high accuracy, reliability and long term stability are required. The wire is wound into a small spiral, and inserted into axial holes in a high purity alumina rod. A small quantity of glass adhesive is applied to these holes, which after firing secures a part of each wire into the alumina. Detectors have been produced by this method as thin as 0.9mm diameter and as short as 6mm with a resistance accuracy of $\pm 0.01\%$. A host of other sizes and shapes are produced. The internal leads of a detector assembly should be constructed of materials dictated by the temperature the assembly will have to withstand. Up to 150°C and 300°C silver leads are preferred, from 300°C to 500°C nickel leads are considered best although the resistance tends to be high, and above 550°C noble metal leads prove most satisfactory.

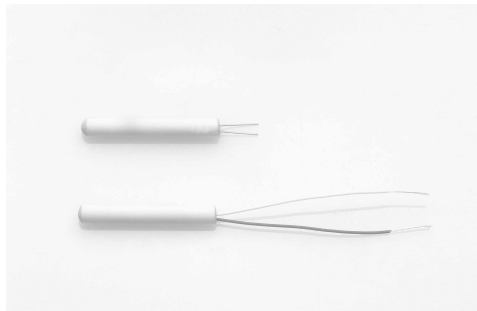

Fig 17: Pt100 Resistors

b) Metal Film Resistors

Metal film Pt resistors take the form of a thin (1 micron) film of platinum on a ceramic substrate. The film is laser trimmed to have a precise R_o value and then encapsulated in glass for protection.

A wide range of styles and dimensions are produced to allow for different applications. Such sensors have fast thermal response and their small thermal mass minimises intrusion in the media being tested. Such sensors are known variously as flat film, thin film or chip sensors.

Thermoelements and resistance thermometer sensing resistors alike normally require protection from environmental conditions and, depending on the application would normally be housed in a suitable sheath material if immersion is required. Alternative housings are used for non-immersion use such as in surface or air sensing.

3.4.2. Connecting Resistance Thermometers to Instruments

Unlike thermocouples, resistance thermometers do not require special cable and standard electrical wires with copper conductors should be used. The heavier the gauge of the conductors, the less the impact is on errors due to lead resistance effects as described. Typically 7/0.2mm or 14/0.2mm conductors are specified with insulation chosen to suit a particular application. Refer to "Terminating the Resistance Thermometer on page 27 for details of the different wiring configurations (2,3 or 4 wire).

Recommended Colour Codes BS EN 60751:1996

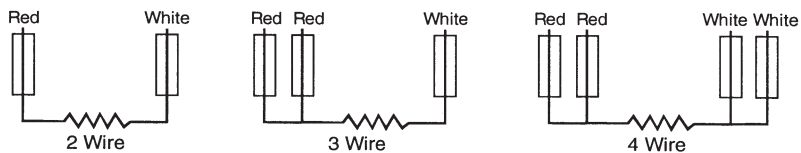

Installation Notes:

- Always observe colour codes and terminal designations; the wiring configuration of the thermometer must match that of the instrument input arrangement.
- Avoid introducing "different" metals into the cabling; preferably use copper connecting blocks or colour coded (or other dedicated) connectors for the greater accuracy, reliability and convenience of installation.
- Use screened or braided cable connected to ground in any installation where ac pick-up or relay contact interference is likely.
- For very long cable runs, ensure that cable resistance can be tolerated by the instrumentation without resulting in measurement errors. Modern electronic instruments usually accept up to 100 Ohms or so for 3 or 4 wire inputs. Refer to the relevant instrument specifications for full details.
- Cabling is usually available with many different types of insulation material and outer covering to suit different applications. Choose carefully in consideration of ambient temperature, the presence of moisture or water and the need for abrasion resistance.

- f) If errors occur, be sure to check the sensor, the cable, interconnections **and** the instrument. Many such problems are due to incorrect wiring or instrument calibration error rather than the sensor.

Interchangeability is facilitated by the use of plug and socket interconnections. Special connectors are available for this purpose.

Guide to Cable Insulation and Coverings

Which insulation Material?	usable temperature range	Application Notes
PVC	-10°C to 105°C	Good general purpose insulation for "light" environments. Waterproof and very flexible.
PFA (extruded)	-75°C to 250°C	Resistant to oils, acids other adverse agents and fluids. Good mechanical strength and flexibility. PTFE better for steam/elevated pressure environments
PTFE (taped & wrapped)	-75°C to 250/300°C	Resistant to oils, acids other adverse agents and fluids. Good mechanical strength and flexibility.
Glassfibre (varnished)	-60°C to 350/400°C	Good temperature range but will not prevent ingress of fluids. Fairly flexible but does not provide good mechanical protection.
High temperature glass fibre	-60°C to 700°C	Will withstand temperature up to 700°C but will not prevent ingress of fluids. Fairly flexible, not good protection against physical disturbance.
Ceramic Fibre	0 to 1000°C	Will withstand high temperature, up to 1000°C. Will not protect against fluids or physical disturbance.
Glassfibre (varnished) stainless steel overbraid	-60°C to 350/400°C	Good resistance to physical disturbance and high temperature (up to 400°C). Will not prevent ingress of fluids.

3.4.4. Performance Considerations When Using Resistance Thermometers

There are various considerations appropriate to achieving good performance from resistance thermometer sensors:

- a) Length of cable runs and loop resistance – Refer to Installation Notes
- b) Interference and Isolation

With long cable runs, the cables may need to be screened and earthed at one end (at the instrument) to minimise noise pick-up (interference) on the measuring circuit.

Poor insulation is manifested as a reduction in the indicated temperature, often as a result of moisture ingress into the probe or wiring.

c) Self-heating

In order to measure the voltage dropped across the sensing resistor, a current must be passed through it. The measuring current produces dissipation which generates heat in the sensor. This results in an increased temperature indication. There are many aspects to the effects of self-heating but generally it is necessary to minimise the current flow as much as possible; 1mA or less is usually acceptable. The choice of current value must take into account the R_s value of the sensing resistor since $\text{dissipation} = I^2R$.

If the sensor is immersed in flowing liquid or gas, the effect is reduced because of more rapid heat removal. Conversely, in still gas for example, the effect may be significant. The self-heating coefficient E is expressed as:

$$E = \Delta t / (R - I^2)$$

where Δt = (indicated temperature) – (temperature of the medium)

R = Pt resistance

I = measurement current

d) Stem conduction

This is the mechanism by which heat is conducted from or to the process medium by the probe itself; an apparent reduction or increase respectively in measured temperature results. The immersion depth (the length of that part of the probe which is directly in contact with the medium) must be such as to ensure that the "sensing" length is exceeded (double the sensing length is recommended). Small immersion depths result in a large temperature gradient between the sensor and the surroundings which results in a large heat flow.

The ideal immersion depth can be achieved in practice by moving the probe into or out of the process medium incrementally; with each adjustment, note any apparent change in indicated temperature. The correct depth will result in no change in indicated temperature.

For calibration purposes 150 to 300mm immersion is required depending on the probe construction.

The use of thermowells increases the thermal resistance to the actual sensor; heat also flows to the outside through the thermowell material. Direct measurements are preferable for good response and accuracy but may be mechanically undesirable.

Low flow rates or stationary media result in reduced heat transfer to the thermometer; maximum flow rate locations are necessary for more accurate measurement.

3.4.5. Surface Temperature Measurement

Resistance thermometers are mainly stem sensing devices with a finite sensing length and as such are best suited to immersion use. However, certain types of sensing resistors can be applied to surface sensing when suitably housed. Thin film devices and miniature wire-wound elements can be used in a surface contact assembly such as those shown below. In such cases, the sensing devices must be held in close contact with the surface whilst being thermally insulated from the surrounding medium. Rubber and PTFE bodies are often utilised for such assemblies. Locating the device on a surface can be achieved in various ways including the use of an adhesive patch and pipe clips. If it is possible to provide lagging (thermal insulation) around the sensor assembly, accuracy will be improved.



Fig 18: Self Adhesive Patch Pt100 Sensor for Surface Temperature Sensing

3.4.6. High Accuracy Measurement

Assuming a 3 or 4 wire connection, and the use of a class B sensing resistor (refer to page 83 for tolerance details), a standard thermometer assembly will provide an accuracy of around 0.5°C between 0°C and 100°C. Considerable improvement on this figure can be achieved by various means including the use of closer tolerance sensors. Reference to the tolerance chart on page 83 will indicate “accuracies” of the standard Class B and Class A devices. However, tolerances of $\frac{1}{3}$, $\frac{1}{5}$ and $\frac{1}{10}$ of the Class B values are available with wirewound and other resistors and these allow for higher precision of measurement. It is important to note that these tolerances are rarely achieved in practice due to stress and strain in handling and assembly, extension lead wire effects and thermal considerations. However, the closer tolerances do provide more precise basic accuracy platforms. Practical overall accuracy of around 0.15°C can be achieved between 0°C and 100°C if a $\frac{1}{10}$ DIN sensor is used.

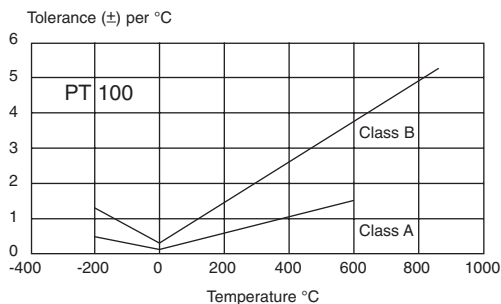

Fig 19: Pt100 Tolerances

System (probe and instrument) accuracy can be optimised by means of calibration and certification which identifies overall measurement errors; such calibrations are usually carried out to international standards.

High precision resistance thermometers are available for laboratory use and accuracies of a few millidegrees can be achieved using such devices. These may use different alpha values and must be calibrated at fixed points. Nominal 10, 25 and special 100 Ohm R_0 versions may be used.

4. NTC THERMISTORS & INFRARED (NON-CONTACT) SENSORS

The **NTC Thermistor** is an alternative to the Platinum resistance thermometer; the name derives from "thermal resistor" and defines a metallic oxide which displays a high negative **temperature coefficient** of resistance. This compares with the small positive coefficient of say Platinum used for the Pt100 sensor. The temperature-resistance characteristic of the thermistor is up to 100 times greater than that of the alternative resistance thermometer and provides high sensitivity over a limited temperature range.

PTC (Positive Temperature Coefficient) versions are also available but their use is much less common than the popular NTC types.

High resistance thermistors, greater than 100kOhms are used for high temperatures (150 to 300°C); devices up to 100kOhms are used for the range 75 to 150°C. Devices below 1kOhm are suitable for lower temperatures, -75 to +75°C.

Thermistors provide a low cost alternative to the Pt100 although the temperature range is limited; interchangeability and accuracy place them between Pt100 and thermocouple alternatives. Since their resistance value is relatively high, a simple 2 wire connection is used.

4.1. RESISTANCE / TEMPERATURE CHARACTERISTIC

The electrical resistance of a NTC (Negative Temperature Coefficient) Thermistor, decreases non-linearly with increasing temperature.

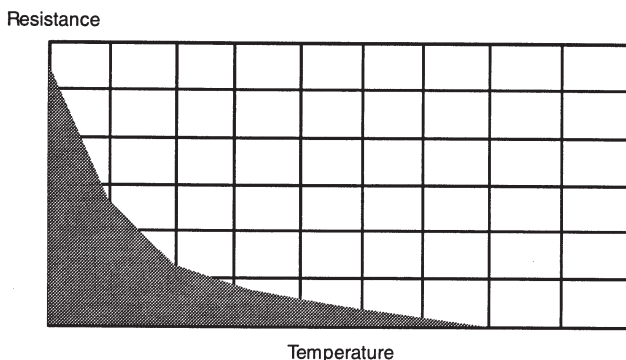

Fig 20: Resistance/Temperature Characteristics of NTC Thermistor

The amount of change per degree Celcius (C) is defined by either the BETA VALUE (material constant), or the ALPHA COEFFICIENT (resistance temperature coefficient).

The Beta Value is defined by:

$$\text{Beta} = \frac{1}{\frac{1}{T_1} - \frac{1}{T_2}} \times \log_n \frac{R_1}{R_2}$$

where T1 and T2 are two specified temperatures, usually 273.15K (0°C) and 323.15K (50°C), and R1 over R2 is the ratio of the measured resistance at the two specified temperatures. Beta is expressed in degrees Kelvin.

The Alpha Coefficient is defined by:

$$\alpha = \frac{1}{R_T} \times \frac{dR}{dT}$$

where T is specified temperature in degrees K, R is resistance at specified temperature T. Alpha value is usually expressed in % per °C. There is a direct relationship between the Alpha Coefficient and the Beta Value.

The larger the Alpha or Beta Value, the greater the change in resistance per °C, (the greater the sensitivity). Within the thermistor industry, a thermistor material system is usually identified by specifying the Alpha coefficient, Beta Value, or the ratio between the resistance at two specified temperatures (typically, RO/R50, R25/R125, RO/R25, R70/R25, or RO/R70).

4.1.1. Electrical Resistivity

Electrical Resistivity (Ohm-cm) is one electrical characteristic of different materials. It is equal to the resistance to current flow of a centimetre cube of a particular material, when the current is applied to two parallel faces. It is defined by the following equation:

$$R = \rho \frac{l}{A}$$

where R is resistance, l is length of a uniform conductor, A is cross-sectional area, and ρ is resistivity .

When comparing different thermistor materials, the material with the larger Alpha or Beta value will generally have the larger resistivity.

Material resistivity is an important consideration when choosing the proper thermistor for an application. The material must be chosen such that a thermistor chip of a specified resistance value will not be too large or too small for a particular application. Thermistor materials are available with a variety of resistivity values. The resistance of an NTC thermistor is determined by material resistivity and physical dimensions. Required resistance value is usually specified at 25°C.

4.1.2. Self-heating

At low measuring current levels, the power dissipated by a thermistor is small and is of little consequence to measurement accuracy. Increased current results in increased dissipation causing the sensor to heat up; an increased temperature is indicated resulting in measurement errors.

General

Probe construction and connection to instruments are as for resistance thermometers but only a 2 wire arrangement is used (lead resistances will be very small compared with sensor resistance).

4.2 INFRARED TEMPERATURE MEASUREMENT

4.2.1 Principles of Infrared Sensing

Energy is radiated by all objects having a temperature greater than absolute zero (-273°C). The energy level increases as the temperature of the object rises.

Therefore by measuring the level of the energy radiated by any object, the temperature of that object can be obtained. For this purpose, energy in the infrared band is used (wavelengths of between 0.5 micron and 20 micron are observed in practice). Emissivity has to be taken in to account when evaluating the temperature using infra-red radiation (described below).

4.2.2. Methods of Measurement

The two most common methods of sensing and measuring temperature on a non-contact, infrared basis are:

- a) Optical pyrometry
- b) Non-contact thermocouple

Optical pyrometry uses comparison techniques to measure temperature ; non-contact thermocouple techniques provide an accurate, convenient and relatively inexpensive alternative.



Fig 20a: Infrared Digital Thermometer

Infrared thermocouples are passive devices which provide a “true” thermocouple output signal appropriate to the type specified (usually type J or type K). Such sensors can therefore be directly connected to the thermocouple input of an instrument but, unlike the standard thermocouple provide convenient, non-intrusive, remote temperature sensing. This approach is usually inexpensive, especially when compared with optical systems. The compact dimensions of these devices makes them as convenient as a thermocouple to install in industrial processes or to use in experiments; hand held sensors are also available.

The detection method used by many infrared thermocouples is similar in principle to that of optical systems, the **thermopile**. A thermopile consists of an array of thermocouple junctions arranged in a high density series matrix; heat energy radiated from the object results in an “amplified” output from the sensor (i.e. a multi-thermojunction signal as opposed to that of a single junction).

The output is scaled to correspond to that of the specified thermocouple type (e.g. approx. $40\mu\text{V}/^\circ\text{C}$ for type K over a limited and reasonably linear range).

Since the sensor receives only infrared radiation energy, the rules of thermal radiation apply and such things as non-linearity and emissivity must be considered.

Linearity: Over a restricted temperature range, the sensor output is sufficiently linear to produce a signal which emulates that of the thermocouple with reasonable accuracy; an accuracy of around 2% can be achieved for a type K non-contact sensor over the range 50°C to 650°C for example.

Emissivity: Emissivity is a parameter which defines how much radiation an object emits at a given temperature compared with that of a **black body** at the same temperature. A **black body** has an emissivity of 1.0; there is no surface reflection and 100% surface emission.

The emissivity of a surface is the percentage of the surface which emits; the remaining percentage of the surface reflects. The percentage though, is expressed as a coefficient hence 100% equivalent to 1.0. All values of emissivity fall between 0.0 and 1.0.

For accurate measurement of different materials, ideally, the emissivity should be taken into account and correction applied. Simple instruments may not allow for this but more sophisticated alternatives incorporate emissivity adjustment.

Other considerations include sensor to object distance / target area considerations and the possible need for sensor cooling in high temperature applications.

5. SHEATH MATERIALS, THERMOWELLS, FITTINGS AND TERMINATIONS

Temperature sensor elements for laboratory and industrial use, whether Pt100 or thermocouple will normally be protected by some form of sheath or housing. A wide range of installation fittings and accessories is available to facilitate installation in the actual process and to permit convenient interconnection with instrumentation.

5.1. CONSTRUCTION OF INDUSTRIAL TEMPERATURE PROBE:



Fig 21: Industrial Temperature Probe and Alternative Thermowells

The assembly illustrated will be externally identical for both Pt100 or thermocouple sensors.

The protection tube (or sheath) houses the thermocouple or Pt100 either directly or indirectly via an insert. Additionally, a thermowell may be utilised for purposes of installing the probe into the process or application.

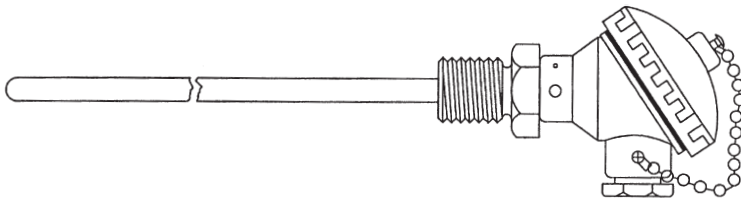

Fig 22: Industrial Temperature Probe with Thread Fitted below the Head

Sensor inserts are fabricated units which comprise a sensor and terminal base; the sensor is housed in a stainless steel insert tube, usually of 6 or 8mm diameter and this is inserted into the actual protection tube. Good seating with physical contact between the insert tip and sheath end is essential to ensure good heat transfer. Spring contact is used in the terminal base to maintain this contact. This arrangement facilitates easy replacement of this sensor as necessary.

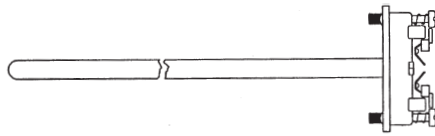

Fig 23a: Sensor Insert

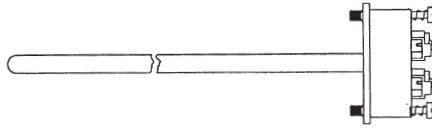

Fig 23b: Sensor Insert with Fitted Transmitter

In the case of a mineral insulated thermocouple or Pt100, the sensor is integral with the insert tube.

When a sensor insert is not specified, the sensor is housed directly in the probe and a suitable insulant is used to achieve electrical and/or thermal isolation from the sheath wall as required. Replacement requires exchanging the entire assembly in this case. A temperature transmitter can be fitted to the terminal base to provide a complete sensor and signal conditioning insert.

A thermowell or pocket can be used to facilitate sensor replacement without disturbance to the process. Fitted permanently into the process via a thread or flange, the thermowell also provides protection for the probe against aggressive media as well as maintaining physical process integrity in the event of probe removal.

The use of a thermowell does impair thermal response to some extent and does not provide a good approach if fast response to temperature changes is required.

5.2. TERMINAL HEADS

Many alternative types of terminal head are available to meet the requirements of various applications. Variations exist in size, material, accommodation, resistance to media, resistance to fire or even explosion and in other parameters. Common types are shown below but there are many special variants available to meet particular requirements.



Fig 24: Terminal Heads, Blocks and Accessories

DIN standard 43 729 defines two such types of head which dominate the European market. Identified as Types A and B. The smaller Type B version, is the most popular and 2 wire transmitters are usually designed to fit inside the DIN B head. Terminal block located in a “head” allow for the connection of extension wires. Various materials are used for screw or solder terminations including copper, plated brass and, for the best performance in the case of thermocouples, thermoelement alloys.

The various head styles cater for a wide variety of probe diameters and cable entries.

Alternative Terminations

Alternatives to terminal heads include extension leads directly exiting probes, plug and socket connections fitted to probes and “tails” (short connecting wires). Cost savings can be thus realised when a head is not required although overall ruggedness may be limited to some extent especially when a direct extension lead is specified. Robust cable types are available.

5.3. SHEATH MATERIALS

Sheath materials range from mild and stainless steels to refractory oxides (ceramics, so called) and a variety of exotic materials including rare metals. The choice of sheath must take account of operating temperature, media characteristics, durability and other considerations including the material relationship to the type of sensor.

The application guide below provides details of various commonly specified sheath materials.

5.3.1. Thermocouple Sheath Materials – Application Guide

Sheath Material	Maximum Continuous Temperature	Notes	Applications
Refractory Oxide recrystallised, e.g. Alumina Impervious	1750°C	Good choice for rare metal thermocouples. Good resistance to chemical attack. Mechanically strong but severe thermal shock should be avoided.	Forging iron & steel. Incinerators carburizing and hardening in heat treatment. Continuous furnaces. Glass Lehrs.
Silicon Carbide (Porous)	1500°C	Good level of protection even in severe conditions. Good resistance to reasonable levels of thermal shock. Mechanically strong when thick wall is specified but becomes brittle when aged. Unsuitable for oxidising atmospheres but resists fluxes.	Forging iron & steel. Incinerators Billet heating, slab heating, butt welding. Soaking pits ceramic dryers.

Sheath Material	Maximum Continuous Temperature	Notes	Applications
Impervious Mullite	1600°C	Good choice for rare metal thermocouples under severe conditions. Resists Sulphurous and carbonaceous atmospheres. Good resistance to thermal shock should be avoided.	Forging iron & steel. Incinerators. Heat treatment. Glass flues. Continuous furnaces.
Mild Steel (cold drawn seamless)	600°C	Good physical protection but prone to rapid corrosion.	Annealing up to 500°C. Hardening pre-heaters. Baking ovens.
Stainless steel 25/20	1150°C	Resists corrosion even at elevated temperature. Can be used in Sulphurous atmospheres.	Heat treatment annealing, flues, many chemical processes. Vitreous enamelling. Corrosion resistant alternative to mild steel.
Inconel 600/800*	1200°C	Nickel-Chromium-Iron alloy which extends the properties of stainless steel 25/20 to higher operating temperatures. Excellent in Sulphur free atmospheres; superior corrosion resistance at higher temperatures. Good mechanical strength.	Annealing, carburizing, hardening. Iron and steel hot blast. Open hearth flue & stack. Waste heat boilers. Billet heating, slab heating. Continuous furnaces. Soaking pits. Cement exit flues & kilns. Vitreous enamelling. Glass flues and checkers. Gas superheaters. Incinerators up to 1000°C. Highly sulphurous atmospheres should be avoided above 800°C.
Chrome Iron	1100°C	Suitable for very adverse environments. Good mechanical strength. Resists severely corrosive and sulphurous atmospheres.	Annealing, carburizing, hardening. Iron & steel hot blast. Open hearth flue and stack. Waste heat boilers. Billet heating, slab heating. Continuous furnaces. Soaking pits. Cement exit flues & kilns. Vitreous enamelling. Glass flues and checkers. Gas superheaters. Incinerators up to 1000°C.

5

Sheath Material	Maximum Continuous Temperature	Notes	Applications
Nicrobell*	1300°C	Highly stable in vacuum and oxidising atmospheres. Corrosion resistance generally superior to stainless steels. Can be used in Sulphurous atmospheres at reduced temperatures. High operating temperature.	As Inconel plus excellent choice for vacuum furnaces and flues.

* Tradenames

5.3.2. Metallic and Non-Metallic Sheath Materials

The choice of metallic or non-metallic sheathing is mainly a function of the process temperature and process atmosphere. Ceramic (non-metallic) tubes are fragile but have a high chemical resistance; they can withstand high temperatures (up to 1800°C in some cases). Metallic tubes, most commonly stainless steels, have mechanical advantages and higher thermal conductivity; they are also generally immune to thermal shock which can easily result in the shattering of ceramic tubes. Depending on the alloy specified, metallic sheaths can be used at temperatures up to 1150°C (higher in the case of rare metals such as Platinum or Rhodium). Ceramics are superior when high purity is required to avoid sensor or product contamination at elevated temperatures (outgassing is minimal or non-existent)

Metallised ceramic tubes are available which endow the ceramic material with greater mechanical strength and surface hardness. Although ceramic based tubes generally display high electrical insulation, some types can become electrically conductive at elevated temperatures. They must therefore not be relied upon for electrical insulation under all conditions.

The temperature sensor and associated connecting wires must be electrically insulated from each other and from the sheath except when a grounded (earthed) thermoelement is specified. Such insulation can take various forms including mineral insulation, wires sleeved in suitable coverings such as glassfibre and ceramic insulators.

Ceramic Sheaths with thermocouple elements

Ceramic tubes, with their comparatively poor mechanical properties, are used when conditions exclude the use of metal, either for chemical reasons or because of excessive temperatures. Their main applications are ranges between 1000 and 1800°C. They may be in direct contact with the medium or may be used as a gas-tight inner sheath to separate the thermocouple from the actual metal protection tube. They should be mounted in a hanging position above 1200°C to prevent distortion or fracture due to bending stresses. Even hair-line cracks can lead to contamination of the thermocouple resulting in drift or failure. The resistance of the ceramic to temperature shock increases with its thermal conductivity and its tensile

strength and is greater for a smaller thermal expansion coefficient. The wall thickness of the material is also important; thin-walled tubes are preferable to larger wall thicknesses.

Cracks are frequently produced by subjecting the protection tubes to excessively rapid temperature changes when they are quickly removed from a hot furnace. The use of an inner and outer sheath of gas-tight ceramic is therefore advisable. The outer thin-walled tube protects the inner one against temperature shock through the air between them. This lengthens the life of the assembly but results in slower response.



Fig 25: Rare Metal Thermocouple

In the case of rare metal thermocouples the ceramic has to be of very high purity. Platinum thermocouples are very sensitive to contamination by foreign atoms. Special care must therefore be taken with fittings for high-temperature measurements to ensure that insulation and protection tube materials are of high purity. Platinum wire must be handled with great care to avoid contamination; grease and metallic contaminants will present a threat at elevated temperatures. Many refractory materials including Aluminium Oxide (Alumina) and Magnesium Oxide (used as an insulant) become electrically conductive at temperatures above 1000°C. The use of high purity materials results in better insulation at elevated temperatures; multi-bore insulators in high grade recrystallised Alumina provide the best solution for thermoelement sleeving. The insulation behaviour of ceramics mainly depends upon their alkali content; the higher the alkali content, the higher the electrical conductivity becomes at even lower temperatures (800°C plus). Ceramics of pure Alumina display the best properties.

5.4. THERMOWELLS

Thermowells provide protection for temperature probes against unfavourable operating conditions such as corrosive media, physical impact (e.g. clinker in furnaces) and high pressure gas or liquid. Their use also permits quick and easy probe interchanging without the need to “open-up” the process.

Thermowells take many different forms and utilise a variety of materials (usually stainless steels); there is a wide variety of thread or flange fittings depending on the requirements of the installation. They can either be drilled from solid material for

the highest pressure integrity or they can take the form of a “thermopocket” fabricated from tubing and hexagonal bushes or flanges; the latter construction allows for longer immersion lengths.



Fig 26: Threaded Thermowells

Thermowells transfer heat from the process to the installed sensor but “thermal inertia” is introduced. Any temperature change in the process will take longer to affect the sensor than if the thermowell were absent; sensor response times are thus increased. This factor must be considered when specifying a thermowell; except when thermal equilibrium exists, a temperature measurement will probably be inaccurate to some extent.

Optimum bore is an important parameter since physical contact between the inner wall of the thermowell and the probe is essential for thermal coupling. In the case of a thermocouple which is **tip sensing** it is important to ensure that the probe is fully seated (in contact with the tip of the thermowell). For Pt100 sensors which are stem sensing the difference between the probe outside diameter and bore must be kept to an absolute minimum.

Response times can be optimised by means of a tapered or stepped-down well which presents a lower thermal mass near the probe tip.

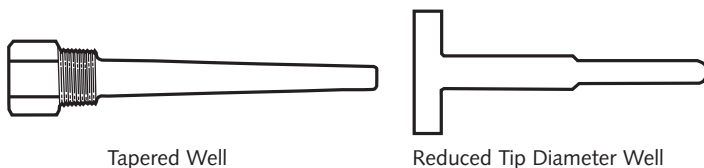

Fig 27: Tapered and Reduced Tip Diameter Well

Process connections are usually threaded or flanged but thermowells can be welded into position.

a) Threaded connections

Parallel or tapered (gas tight) threads make for convenient installation into a welded-in fitting directly into the process. Such a connection is suitable for smaller diameter wells which are not likely to be changed frequently (e.g. where corrosion rates are low). A hexagon is used at the top of the well for ease of fitting.

An extended hexagon length can be used to allow for insulation thickness. Typical thread sizes are $\frac{1}{8}$ " BSP (T), $\frac{1}{2}$ " BSP (T) or 20mm.

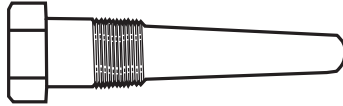

Fig 28: Tapered Thread Well

b) Flanged Connections

Flanged connections are preferable if there is a need for more frequent well replacement such as high corrosion rates. The flange bolts to a mating flange mounted on the process. Such a technique is more appropriate for large pipe diameters and for high pressure applications. Flanges are usually of 2 to 3 inches in diameter.

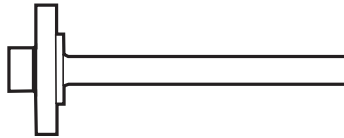

Fig 29: Flanged Parallel Well

c) Welded Connections.

Welded connections can be used when the process is not corrosive and routine removal is not required. High integrity is achieved and this technique is suitable for high temperature and high pressure applications such as steam lines. Removal of a welded-in well usually involves considerable effort and time.



Fig 30: Weld-in Well

Lagging extensions are provided on thermowells (or even directly on probe assemblies) for use on lagged processes. A lagging extension distances the terminal head from the immersion part of the assembly to allow for the depth of lagging (thermal insulation). This technique is useful in allowing the head, perhaps with an integral transmitter, to reside in a cooler ambient temperature region rather than adjacent to the much hotter process.

Lagging extensions take various forms depending on overall probe or well construction, fitting method and type of termination.

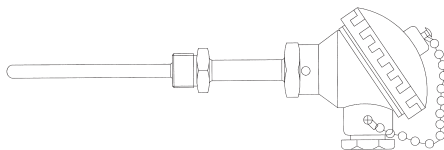

Fig 31: Industrial Probe with Flange and Lagging Extension

5.5. FITTINGS

Installing temperature sensor assemblies into thermowells or directly into the process requires the use of some kind of brass or stainless steel fitting.



Fig 32: Installation Fittings

Fittings include various threaded unions, bayonet caps (and adapters) and flanges.

Adjustable compression fittings are used directly on probes to achieve the required insertion length in the process and to ensure the proper seating of probes into thermowells.

Adjustable flanges can similarly be used to secure the sensor assembly into the process. **Bayonet caps** provide a method of quick fitting into suitable adapters located in the process; this technique is widely used in plastics machinery.

Bushes and hexagon plugs are used when adjustment or removal is a lesser consideration.

The choice of fitting may be dictated by the need for pressure integrity or by physical size constraints. Compression fittings and threaded bushes can be supplied with tapered threads to achieve a pressure-tight connection.

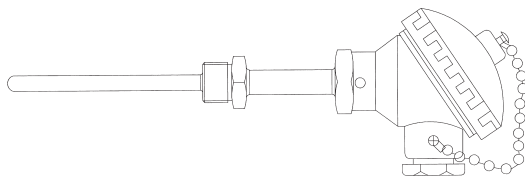

Fig 33: Industrial Probe with Mounting Fitting

5.6. INTERCONNECTIONS

Connections between the thermocouple or Pt100 and associated instruments may involve a physical interface with installed wiring and/or sensors. Such interfaces take the form of special connectors, terminal strips, barrier blocks and extension cables.

Due to their location in often adverse environments such as hot working zones of furnaces and machinery, temperature sensors are liable to corrosion and mechanical damage. The need for occasional replacement is inevitable and the use of suitable polarised connectors permits error-free, fast, positive and reliable interchange with no risk of dangerous cross connection.

Plugs and sockets for this purpose are produced to internationally recognised patterns, namely standard (round pin) and miniature (flat pin) versions. Ideally, connectors from the various manufacturers will interconnect directly and be fully compatible; generally, this is achieved. Many variants of the in-line connectors are produced including 3 and 4 pin versions, panel-mounting types and a wide range of multi-way panels and accessories.

Colour coding of the connector bodies is utilised to ensure clear identification of each thermocouple type since the pins and receptacles will normally be of the appropriate thermocouple alloy or compensating material; an international standard IEC584-3 1989, mod. defines these colours for thermocouples. The colour for connector bodies are expected to align with the specified colours but are not expected to be a precise match; such matching is difficult to achieve in mass production mouldings although colours to ANSI/MC96.1 presently dominate the USA markets. The use of the appropriate thermocouple alloys eliminates measurement error due to interconnection via different metals.

The connectors can be mounted directly on to the “cold end” of probes or fitted to extension cables. Good quality products should withstand up to 220°C continuous operation although some manufacturers do not offer such a high temperature rating.

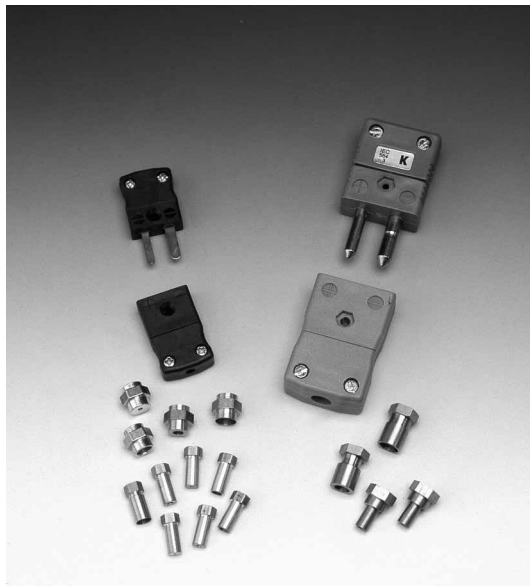

Fig 34: Connectors and Probe Fittings



Fig 35: Panel Mounting Connector

Barrier Terminals and DIN style terminal blocks used in DIN pattern heads are also available with colour coded bodies and connections in thermocouple alloys. Their use instead of those with copper or brass connections will result in improved accuracy throughout the thermocouple circuit.

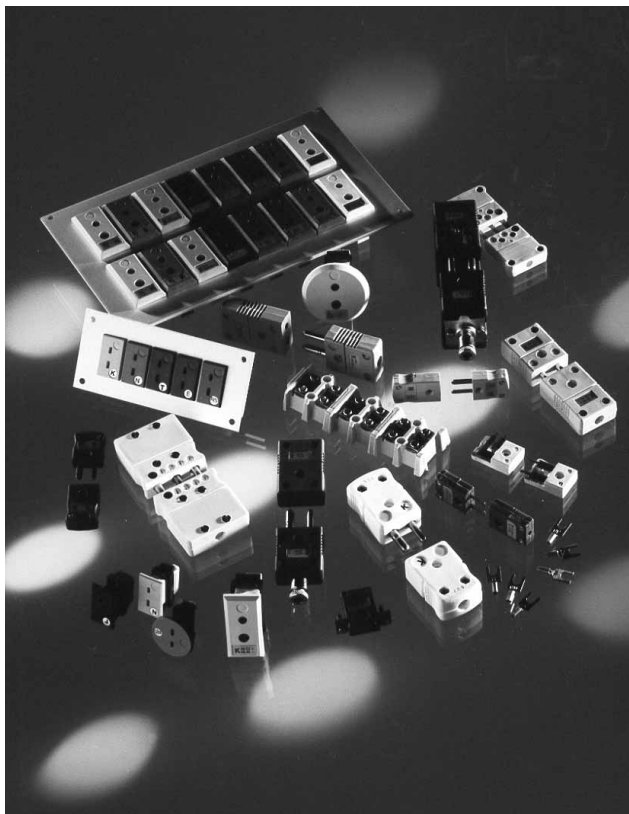

Fig 36: Connectors and Accessories

Connectors and terminal blocks are available with copper conductors for use with Pt100 Sensors. Body colours are not subject to any international standard but white is generally used as distinct from the thermocouple colours.

Full colour photographs at the front of this publication indicate various colour coded connection products.

6. TEMPERATURE CALIBRATION

Temperature calibration provides a means of quantifying uncertainties in temperature measurement in order to optimise sensor and/or system accuracies.

Uncertainties result from various factors including:

- a) Sensor tolerances which are usually specified according to published standards and manufacturers specifications.
- b) Instrumentation (measurement) inaccuracies, again specified in manufacturers specifications.
- c) Drift in the characteristics of the sensor due to temperature cycling and ageing.
- d) Possible thermal effects resulting from the installation, for example thermal voltages created at interconnection junctions.

A combination of such factors will constitute overall system uncertainty. Calibration procedures can be applied to sensors and instruments separately or in combination.

Calibration can be performed to approved recognised standards (National and International) or may simply constitute checking procedures on an “in-house” basis. Temperature calibration has many facets, it can be carried out thermally in the case of probes or electrically (simulated) in the case of instruments and it can be performed directly with certified equipment or indirectly with traceable standards.

Thermal (temperature) calibration is achieved by elevating (or depressing) the temperature sensor to a known, controlled temperature and measuring the corresponding change in its associated electrical parameter (voltage or resistance). The accurately measured parameter is compared with that of a certified reference probe; the absolute difference represents a calibration **error**. This is a **comparison** process. If the sensor is connected to a measuring instrument, the sensor and instrument combination can be effectively calibrated by this technique. Absolute temperatures are provided by **fixed point** apparatus and comparison measurements are not used in that case.

Electrical Calibration is used for measuring and control instruments which are scaled for temperature or other parameters. An electrical signal, precisely generated to match that produced by the appropriate sensor at various temperatures is applied to the instrument which is then calibrated accordingly. The sensor is effectively **simulated** by this means which offers a very convenient method of checking or calibration. A wide range of calibration “simulators” is available for this purpose; in many cases, the operator simply sets the desired temperature and the equivalent electrical signal is generated automatically without the need for computation. However this approach is not applicable to sensor calibration for which various **thermal** techniques are used.

6.1. CERTIFICATION

Officially recognised (accredited) calibration laboratories are authorised to perform certain types of calibration and to issue the appropriate certificate. Such calibrations are carried out in accordance with appropriate standards, for example UKAS in the U.K. and DKD in Germany. The certificate issued for each sensor will state any calibration error which is measured at the various test temperatures and also the uncertainties which exist in the measurement system used for the calibration.

6.2. THERMAL TEMPERATURE CALIBRATION

Essentially the test probe reading is compared with that of a certified reference probe whilst both are held at a common, stable temperature. Alternatively, if a fixed point cell is used, there is no comparison with a certified thermometer; fixed point cells provide a highly accurate, known reference temperature, that of their phase conversion.

6.2.1. Equipment required for a Calibration System.

The equipment required to achieve thermal calibration of temperature probes is dependent on the desired accuracy and also ease of use. The greater the required accuracy, the more demanding the procedure becomes and of course, the greater the cost.

The required equipment generally falls into one of three groups:

1. **General purpose system** for testing industrial plant temperature sensors will usually provide accuracies between 1.0°C and 0.1°C using comparison techniques.
2. **A secondary standards system** for high quality comparison and fixed point measurements will provide accuracies generally between 0.1°C and 0.01°C.
3. **A primary standards system** uses the most advanced and precise equipment to provide accuracies greater than 0.001°C

A typical general purpose system comprises:

- * A thermal reference (stable temperature source)
- * A certified Pt100 reference probe complete with its certificate.
- * A precision electronic digital thermometer, bridge or DVM (digital voltmeter)

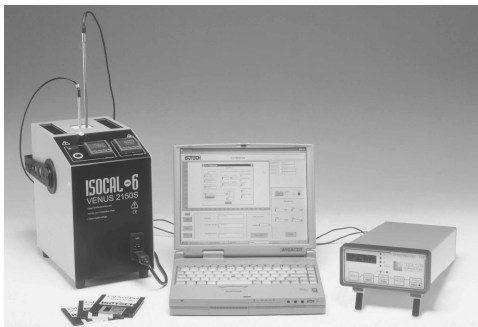

Fig 37: General Purpose Calibration System using a dry block calibrator

A convenient form of **thermal reference** is the dry block calibrator. Such units are available with various ranges spanning from -50°C to $+1200^{\circ}\text{C}$ and have wells to accept various test and reference probe diameters. Alternative temperature sources for comparison techniques include precisely controlled ovens and furnaces and stirred liquid baths.

Dry Block Calibrators

Dry block calibrators provide the most convenient, portable facilities for checking industrial probes and they usually achieve reasonably rapid heating and cooling. The units consist of a specially designed heated block within which is located an insert having wells for the probes. The block temperature is controlled electronically to the desired temperature. The whole assembly is housed in a free-standing case.

Although the block temperature is accurately controlled, any indication provided should be used for guidance only. As with any comparison technique, a certified sensor and indicator should be used to measure the block temperature and used as a reference for the test probe.

Two types of unit are available; portable units which can be taken on to plant for on-site calibration and laboratory units to which industrial sensors are brought as required.



Fig 38: Dry Block Calibrator

Alternative “temperature” sources.

Many laboratory furnaces and ovens are available which are specially designed for temperature calibrations. Precisely controlled, they feature isothermal or defined thermal gradient environments for probes.

Stirred liquid baths provide superior thermal environments for probe immersion since no air gaps exist between the probe and medium. Thermal coupling is therefore much better than the alternatives described and stirring results in very even heat distribution throughout the liquid

Alcohols are used for temperatures below 0°C , water from 0°C to 80°C and oils for up to 300°C . Various molten salts and sand baths are used for temperatures in excess of 300°C .

A Reference Standard Platinum Resistance Thermometer is a specially constructed assembly using a close tolerance Pt100 sensing resistor or a specially wound platinum element with a choice of R_0 values. Construction is such as to eliminate the possibility of element contamination and various techniques are utilised to this end such as special sheath materials, gas filling and special coil suspension.

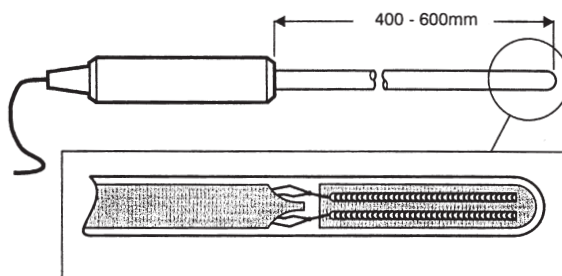

Fig 39: Standard Platinum Resistance Thermometer

Precision Temperature indicators are available in a wide variety of configurations and with alternative accuracy and resolution specifications. By definition, such instruments must be highly accurate and very stable. Normally, the performance of the measuring instrument will be superior to that of the reference sensor to avoid compromising the system performance. As with any measuring system, such factors must be considered when specifying system components.

Developments in high precision digital thermometry have resulted in a high level of "user-friendliness". Features of such instruments can include built-in automatic cold junction compensation with very high stability which allows direct connection to thermocouples without the need for an ice point reference. Another benefit is that of non-volatile memory facilities for storing correction values of certified probes; when this is done, the test probe readings can be directly compared with the corrected reference probe values without the need for user computations. Such a feature enhances the accuracy on reliability of readings.

Communications for data transfer and/or remote control and PC software are sometimes available to further enhance the versatility of the modern electronic thermometer.



Fig 40: High Precision Digital Thermometer

Thermocouple readings can alternatively be taken using a digital volt-meter; in this case, readings are displayed in microvolt units and calculations must be performed for cold junction temperature and characterisation in order to obtain a true temperature measurement.

PRT resistances can be measured using a precision bridge instead of a temperature indicator; again calculations must be performed to obtain temperature measurements.

6.2.2. Fixed Points

Fixed points are the most accurate devices available for defining a temperature scale. Fixed point devices utilise totally pure materials enclosed in a sealed, inert environment; they are usually fragile and need to be handled with care. They work in conjunction with apparatus which surrounds them and provides the operational conditions required for melting and freezing to obtain the reference plateaux. The housings incorporate isothermal blocks with wells into which the probes are placed. Since fixed point temperatures are defined by physical laws, comparison of the test probe to a reference probe is not required.

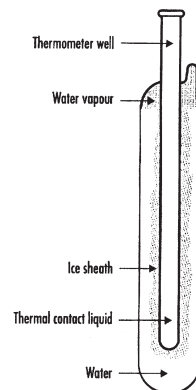

Fig 41: Triple Point of Water Cell

ITS 90 Fixed points include:

Boiling point of Nitrogen	-195.798°C
Mercury triple point	-38.8344°C
Triple point of water	0.01°C
Melting point of Gallium	29.7646°C
Freezing point of Indium	156.5985°C
Freezing point of Tin	231.928°C
Freezing point of Lead	327.462°C
Freezing point of Zinc	419.527°C
Freezing point of Antimony	630.63°C
Freezing point of Aluminium	660.323°C
Freezing point of Silver	961.78°C

All such fixed point apparatus is available commercially.

6.2.3. Electrical Calibration – Simulators and Sources.

Indicators and controllers are calibrated by injecting signals which simulate thermocouples, resistance thermometers or thermistors. A simulator provides a very quick and convenient method for calibrating an instrument at many points. Very sophisticated and highly accurate laboratory instruments are available; conversely, compact and convenient portable units are available to permit on-site checking and calibration with a good level of accuracy.

Calibrator/simulators can be either blind (without indication) or with a built-in indicator. In many cases, such instruments can be used for measuring the temperature sensed by thermocouples and resistance thermometers in addition to providing calibration signals.



Fig 42: Calibration/Simulator

7. TRANSMITTERS AND INSTRUMENTATION

Temperature instrumentation, including temperature transmitters is briefly described in this chapter for purposes of guidance only. It is not intended to be a thorough treatment which would require a volume or volumes to achieve. Reference should be made to appropriate books such as Instrumentation Reference Book published by Butterworth Heinemann for comprehensive guidance. This and other relevant publications are available from the Institute of Measurement and Control.

The sensor, whether thermocouple, Pt100 or thermistor is, in many ways the most important component of a measurement system. Clearly the failure of any item in the system will render it inoperative but, because the sensor will usually be exposed to a harsh environment, compromise may be impossible. For example, a wide range of instruments will almost certainly provide a choice of price and specification but there may be little such choice in the sensor. The overall system accuracy and stability will be no better than that of the sensor.

Instrumentation requirements range from a simple display of a single temperature value to multi-sensor data acquisition and logging or from a simple controller to multi-zone communicating control systems. Other requirements may include transmission and signal conditioning, analogue recording, alarm monitoring and communications.

Fundamentally, instrumentation will be in one of two forms, **open loop** or **closed loop**. **Open loop** is where there is no system feedback and therefore no control action; the measuring instruments exerts no influence over the process behaviour other than possible alarm action which may result in "power-down". **Closed loop** is where there is direct or indirect feedback from the instrument to the process energy regulator resulting in control of the process temperature.

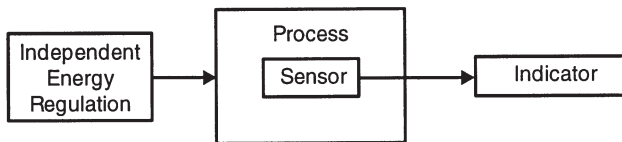

Sensor simply provides temperature information to the indicator.
Process regulation is effected independently.

Fig 43: Open Loop System

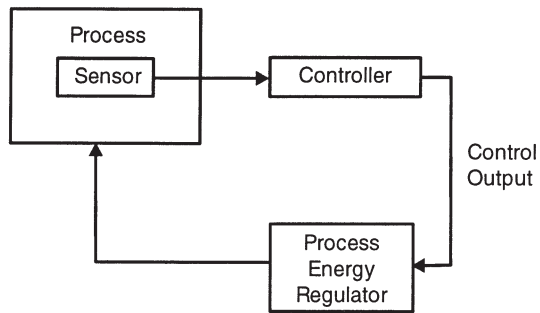

Sensor provides temperature feedback thus allowing automatic control.

Fig 44: Closed Loop System

7.1. SENSOR CONSIDERATIONS WITH INSTRUMENTATION.

Since most modern electronic (often microprocessor based) measuring and controlling instruments offer high accuracy and stability, great consideration must be given to the choice of temperature sensor to realise the performance potential. When specifying any system, a desired accuracy must be stated and all components be considered accordingly. For example, the use of a low-cost base metal thermocouple with $\pm 2.5^\circ\text{C}$ short term accuracy is pointless if extra money is spent to procure a 0.1°C accuracy controller when a 1°C accuracy instrument at lower cost would suffice.

Note however that the theoretical overall accuracy of a system is the sum of the individual accuracies of the system components. If a simple measurement system is structured as follows:

Nominal overall accuracy = accuracy of (thermocouple + transmitter + indicator)

e.g. Overall accuracy = $\pm 2.5^\circ\text{C} \pm 2^\circ\text{C} \pm 1^\circ\text{C}$ say Overall accuracy = $\pm 5.5^\circ\text{C}$ **worst case.**

In practice, this figure may be pessimistic; e.g. If the actual realised accuracies are $+2^\circ\text{C} -1^\circ\text{C} +0.5^\circ\text{C}$ respectively-Actual accuracy at start up would be $+1.5^\circ\text{C}$. However worst case values must be borne in mind when specifying the components. It is clear from this example that in order to obtain good overall accuracy, the main emphasis must be placed on optimising the sensor accuracy. For example by means of:

a) Specifying a calibrated sensor if necessary (this will define **actual** accuracy).

- b) and/or specifying a higher accuracy sensor such as close tolerance version of either thermocouple or Pt100.
- c) and/or specifying a Pt100 instead of a thermocouple if the application permits and if the instrumentation can be specified to suit.
- d) Specifying a type of thermocouple with better basic accuracy and stability than say the standard type K. Examples are type T, N, R and S. However, suitability for the working temperature must be observed.

Note: Wiring and instrument input type must be considered when choosing the type of sensor.

7.2. TRANSMITTERS AND SIGNAL CONDITIONING

Temperature transmitters are widely used in measurement systems because their use allows long cable runs back to the associated instrumentation. They also perform a **signal conditioning** function.

A 2 wire temperature transmitter accepts a thermocouple or 3 wire Pt100 input and converts the "temperature" output into a 4-20mA current signal. The transmitter usually requires a 24Vdc supply which is connected in series with the 2 wire interface (or is provided by the host instrument). The amplified temperature signal can be transmitted via a long cable run if required, a considerable advantage with large site installations.

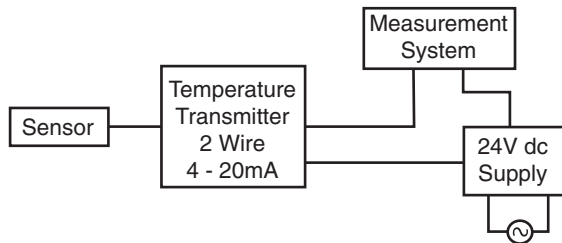

Fig 44a: Temperature Transmitter Circuit

The output can be either linear with temperature (usually the case with Pt100 inputs) or linear with thermocouple voltage (not linear with temperature - usually the case with thermocouple inputs). It is important to ascertain linearity or otherwise since this will have ramifications as far as the indicator is concerned, if the interface is non-linear with temperature, the indicator must display the appropriate transfer characteristic in order to give an accurate temperature readout (e.g. scaled for the Type K curve).

Transmitter scaling must be specified as required e.g. 0 to 400°C = 4 to 20mA. Remember this must correspond to the instrument scaling to avoid measurement errors. ***Input to output isolation is not necessarily incorporated as standard and it is essential to use electrically insulated sensors if isolation is not incorporated.***

Signal conditioning is the process of modifying the raw input signal in one or more ways to facilitate communication and measurement. The transmitter is a simple form of signal conditioner but signal conditioners usually provide linearisation scaling facilities and other functions. The most common form of signal conditioner housing is a DIN rail mounting module.

Signal conditioners are particularly useful when different parameters are measured in a process (e.g. Pt100 and thermocouple outputs, flow rates, pressure and force). The output from all of the appropriate sensors or transducers can be rationalised into a common interface such as 4-20mA or 1-5V. Transfer characteristics can also usually be applied to suit a range of sensors and transducers resulting in a linear function. On this basis, standard process indicators can be utilised thus simplifying the instrumentation.

Programmable and so called “smart” transmitters effectively combine transmission and signal conditioning functions. In addition to manipulating the input-output function, a variety of transmission modes can be selected. Isolation of input to output further enhances their scope of applications; for example a multi-sensor installation with individual transmitters can be used without danger of earth loops establishing spurious potentials. Programming is performed via a PC using software normally supplied or via a plug-in module,

7.3. INSTRUMENTATION & DATA COMMUNICATIONS & EMC

Many microprocessor based indicators and controllers are user configurable for many thermocouple types and, in some cases for Pt100 as well. If the input type is not user selectable, it is essential that this is specified to suit the associated sensor. Ideally the sensor type should define the instrument, not vice versa; this is because the sensor must be chosen to suit the process. In practice, both should be considered to ensure optimum accuracy and cost-effectiveness.

7.3.1. Temperature Measurement & Control

Instrumentation for temperature measurement accept input signals directly or indirectly (via transmitters) from the sensor. The input requirements are different for the alternative signals, Pt100, thermistor, thermocouple or transmitter. Indication can be either analogue (usually a drum scale or recorder chart) or digital and various options are available for the user to extend the functions beyond mere indication. Such options include single or multiple alarms and digital or analogue outputs (communications).

Single or multiple input instruments are available; for multi-channel inputs, selection can be either manual or automatic as with multiplexers and scanners. If isolation is not provided between inputs or between input and output the use of insulated (isolated) probes should be considered.

Scanning, logging and data acquisition Systems are basically electronic measuring instruments with some form of input multiplexing and appropriate storage or re-transmission of the measured temperatures. Alarm functions are usually incorporated. Section 7.3.2. provides more information.

Chart Recorders provide a hard copy record of process temperature often in addition to many other functions such as digital real-time displays and alarms. Such records are a legal requirement in some industries such as food and drug production. Sophisticated recorders have multi-channel capability and various analytical functions.

Temperature Alarms provide for indication of and some form of output switching in the event of the process temperature using above of falling below certain specified limits. They are used for process safety and product quality purposes, often as an adjunct to control systems by way of an independent "policeman".

Where high precision thermometry is required, more expensive **high accuracy instruments** are available. Designed primarily for laboratory use, such indicators provide a high resolution display of temperature and very good stability. The use of such instruments is described in **Chapter 6, Temperature Calibration**.



Fig 45: High Accuracy Digital Thermometer

Automatic Cold Junction Compensation

Temperature measurement instrumentation almost invariably incorporates some form of automatic cold junction compensation for thermocouple inputs. As described in Chapter 2, thermocouple measurements must be referred to a 0°C "cold" junction in order to give a true "hot" junction value. This is achieved in practice by incorporating a compensating circuit; this measures the actual ambient temperature (very rarely 0°C) at the thermocouple input terminals of the instrument and effectively adds the equivalent thermal e.m.f. to that of the thermocouple. This occurs continuously to compensate for both the value of ambient temperature and

for its variations. The resulting indicated temperature is therefore a true representation of the process temperature.

The quality of this compensation is normally expressed as a **rejection ratio** or **temperature coefficient**. A rejection ratio of say 25:1 specifies that a 25°C change in ambient temperature would result in a 1°C change in indicated (measured) temperature. The higher the rejection ratio, the better the compensation. A figure of 20:1 to 25:1 is typical and usually adequate; higher performance instruments can achieve 75:1 or better. The stability may be expressed as say 0.05°C/°C which is equivalent to 20:1.

Temperature Control

A temperature controller is effectively a combination of temperature indicator and added control board with some form of output circuit. The preceding **Temperature Measurement** copy is therefore applicable to this **control** explanation as far as indicators and measurement aspects are concerned.



Fig 46: PID Temperature Controller

The principles of temperature control are treated in some depth in chapter 8 which should be referred to for an explanation of P.I. and D terms and more detail.

The addition of a control and output circuit to the measurement instrument permits **closing of the loop** to achieve closed loop automatic control of a process. Process energy can be derived from electricity, gas or oil and it is the function of the output stage to regulate it as appropriate.

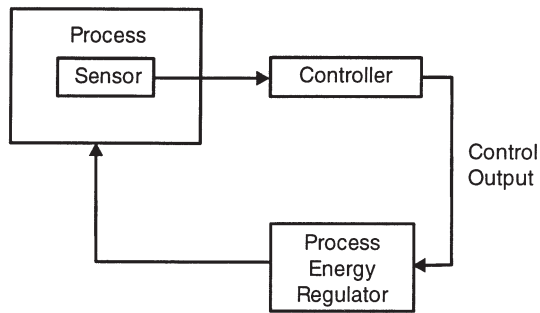

Sensor provides temperature feedback thus allowing automatic control.

Fig 47: Closed Loop System

The diagram above illustrates a simple, single loop control system. Loops may be more complex and many installations will use multi-loop configurations; however, the basic concept is the same.

The control circuit applies either on-off or a combination of proportional (P), integral (I) and derivative (D) functions as described in Chapter 8 to achieve the best possible control of process temperature. The output stage is instructed by the control circuit to apply or remove energy to or from the process accordingly by one of the various “switching” modes available.

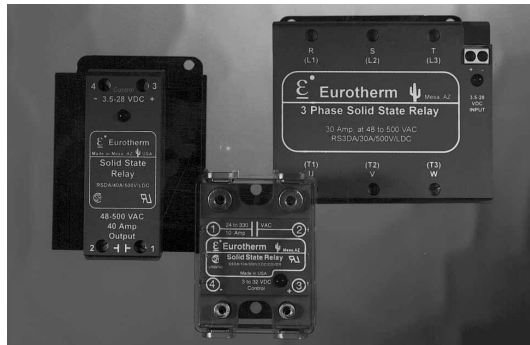

Fig 48: Solid State Power Switches for Electrical Heaters

Electrical energy is ultimately regulated via solid state switches (triacs; thyristors or solid state relays) or via electromechanical relays or contactors. The actual switching device maybe external to the controller in which case control signals are issued by the output circuit (e.g.0-1V, 4-20mA, logic signal or pulses).

Gas or oil are regulated by solenoid valves or proportional motorised valves and the controller issues electrical control signals to suit (voltage or current).

The **process temperature** is normally displayed digitally although some instruments provide some form of analogue indication (drum scale or deviation indication). The **desired temperature (set-point)** is set via analogue or digital adjustment.

7.3.2. Data Acquisition & Logging

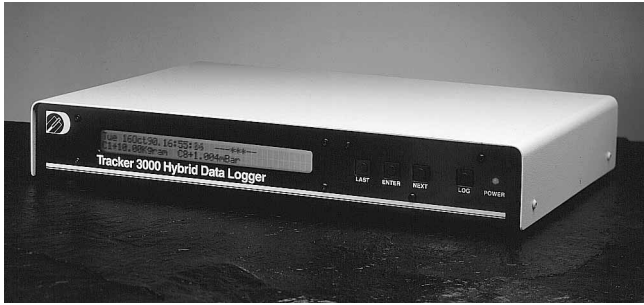

Fig 49: Data Logger

Data acquisition is the process of gathering data from a variety of transducers or sensors for monitoring, storage or processing. A data logger is a stand-alone instrument for data gathering and storage. Logging is simply recording the data with a time/date stamp such that the data can be displayed, printed, analysed and archived as required.

In the case of temperature, a typical application would be some form of experiment which involved any number of temperature sensors (e.g. thermocouples, resistance thermometers, thermistors). An event would require “collecting” measurements from any or all of the sensors at a specified sampling rate for subsequent analysis. Data storage is very important in long term projects.

When specifying a data acquisition system, considerations include the number and type of inputs and outputs, communications protocols, sampling speeds and data storage methods. Such a system can be “stand-alone” or a “front-end” for use in conjunction with a personal computer (PC). Digital printer or analogue chart recorders can be used to print-out data either on a real-time basis or from stored data.

The chosen sampling rate (the rate at which signals from the input transducers are scanned and acquired) needs to be consistent with the dynamics of the process, response times of the transducers and the multiplexing capability of the system.

In the case of remote sensing such as on a large site, radio telemetry is often used to transmit the measured data to the data acquisition system. Supervisory Control and Data Acquisition (SCADA) systems monitor and record data in the same way but additionally are programmed for real-time, on-line decision making, process control activity and alarm monitoring.

7.3.3. Data Communications & Analogue Retransmission

Analogue Outputs from measuring and control instruments are not data communications in the strict definition of the term. However, analogue (retransmission) signals are commonly used for outputting the scaled and amplified process variable to chart recorders and data loggers. Such signals are typically 0-1V dc or 4-20mA dc.

Data Communication is used for transferring data and instructions between associated instruments or between instruments and computers, usually PCs.

Data characters are represented by a data code, each element of which consists of a group of binary digits (bits) each being 1 or 0. The group of bits is called a byte or word. The task of data transmission is to send bytes from one point to another (e.g. instrument to PC).

Data communication is performed as either serial or parallel communication depending on the configuration provided by the indicator or controller and/or the requirements of the application. **Parallel communication** refers to data bits transmitted via separate lines for each bit and therefore utilizes several wires (an 8 bit word requires 8 lines).

Serial Communication refers to data bits transmitted serially through a single line and therefore utilizes a single pair of wires. Examples of widely used recommended standard (RS) include RS-232C, RS-422A and RS-485.

- a) RS-232C is perhaps the most common standard as specified by EIA (Electronics Industries Association). It is used for interfacing between data terminal equipment and data communications equipment. A maximum line length of 15m is permitted. It is a single, bi-directional serial interface.
- b) RS-422A, another EIA standard, specifies a low impedance differential signal permitting a line length of around 1200m. It is a single, bi-directional serial interface.
- c) RS-485 is another EIA standard which specifies the interface characteristics but allows the equipment designer to choose the desired protocol. This enables users to configure multi-drop and local area network communications to suit different applications. It is a multi-drop, bi-directional, serial interface with a capacity of up to 32 transmit / receive drops per line. Developments of serial data communications for industrial applications include HART, MODBUS and other examples developed by leading manufacturers.

HART (Highway Addressable Remote Terminal) is used with "smart", analogue process control instruments for example. MODBUS is an alternative versatile, industrial networking system.

For more information on digital communications, the Institute of Measurement & Control can supply details of a wide range of suitable publications.

7.3.4 Electro-Magnetic Compatibility (EMC)

EMC Requirements for Electrical Equipment for Measurement, Control and Laboratory Use.

Temperature instruments in common with all types of instrumentation must comply with European EMC (Electro-Magnetic Compatibility) regulations in terms of electromagnetic radiation if they are to be available in the European market. The regulation in question is IEC 1326-1. Accordingly, CE marking which indicates compliance, is mandatory.

The regulation is basically that electrical / electronic equipment must not generate significant amounts of electromagnetic radiation (including r.f.i) nor be sensitive to its effects. Standards published accordingly define the requirements, test procedures and various aspects covering both emission and immunity.

Equipment within the scope of the regulations can be subjected to electromagnetic disturbances (EMI), conducted by measurement or control lines or radiated from the environment. The types and levels of disturbances depend on the prevailing conditions in which the equipment operates. Such equipment can also be a source of electromagnetic disturbance over a wide frequency range; again, such energy can be conducted through signal lines or directly radiated and this can affect other equipment. Emissions must be minimized to ensure that interference with normal operation of other equipment does not occur. EMC defines three basic aspects of interference

- a) A **source** which generates an interference signal
- b) A **recipient** which is adversely affected by the signal
- c) A **path** which carries the signal

Interference can be INTRASYSTEM where each aspect is in a separate system. Interference sources can be various in form – natural, man-made intentional (e.g. radio waves) and unintentional (e.g. power lines). Similarly recipients can be either intended or unintended.

The path can be conduction or radiation or a combination of both.

The key elements are defined as:

EMC Electro-Magnetic Compatibility. The condition which exists when a piece of electrical equipment neither malfunctions nor causes malfunction in other equipment when operating in surroundings for which it was designed.

EMI Electro-Magnetic Interference. The unintentional interaction between a piece of electrical equipment and its electromagnetic surroundings.

8. TEMPERATURE CONTROL

8.1. CONTROL LOOPS EXPLAINED

Whatever the process or the parameter (temperature, flow, speed for example), the principles of control are similar. Input and output signals are specified as appropriate to the application, usually analogue (e.g. thermocouple signal input, solid state output power control) but these may be digital.

This chapter assumes temperature control with either a thermocouple or platinum resistance thermometer input and a proportional control output.

Control of a process is achieved by means of a closed loop circuit (power fed to the heater is regulated according to feedback obtained via the thermocouple) as opposed to an open loop in the case of measurement only:

Temperature Measurement (Open Loop)

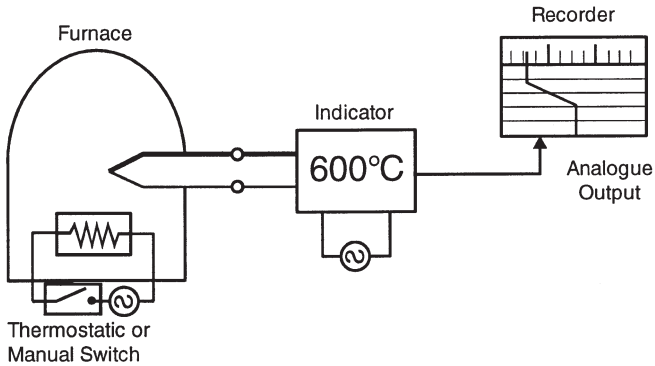

Fig 50: Temperature Measurement (Open Loop)

Temperature Control (Closed Loop)

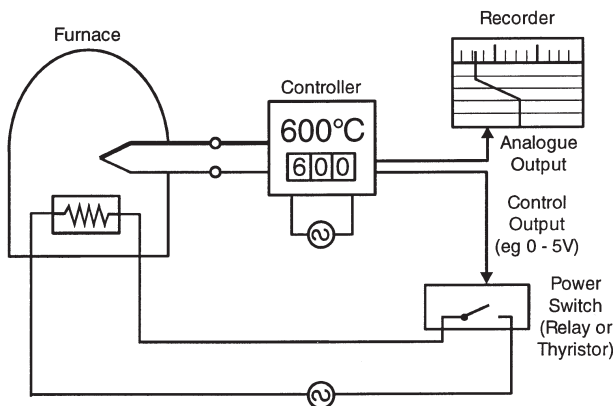

Fig 51: Temperature Control (Closed Loop)

8.2. PID EXPLAINED

With few exceptions, only very crude control of temperature can be achieved by causing heater power to be simply switched on and off according to an under or over temperature condition respectively. Ultimately, the heater power will be regulated to achieve a desired system temperature but refinement can be employed to enhance the control accuracy.

Such refinement is available in the form of **proportional (P), integral (I), and derivative (D)** functions applied to the control loop. These functions, referred to as control “terms” can be used in combination according to system requirements. The desired temperature is usually referred to as the “set-point” (SP) and the measured temperature is usually called the “process variable” (PV).

To achieve optimum temperature control whether using on-off, P,PD or PID techniques, ensure that:

- Adequate heater power is available (ideally control will be achieved with 50% power applied!)
- The temperature sensor, be it thermocouple or PRT, is located within reasonable “thermal” distance of the heaters such that it will respond to changes in heater temperature but will be representative of the load temperature (the “thing” being heated).
- Adequate “thermal mass” in the system to minimise its sensitivity to varying load or ambient conditions.
- Good thermal transfer between heaters and load.
- The controller temperature range and sensor type are suitable – try to choose a range that results in a mid-scale set-point.

Control Functions Simply Described

- On – Off** – Usually simplest and cheapest but control may be oscillatory. Best confined to alarm functions only or when “thermostatic” type control is all that is required, but this may be the most suitable means of control in some applications.

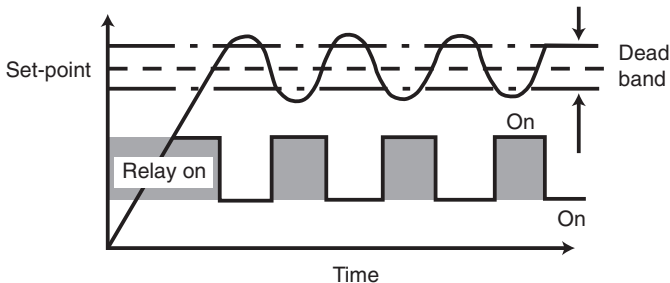

Fig 52: On/Off Control with Dead-Band

- b) **Proportional (P)** – A form of anticipatory action which slows the temperature rise when approaching set-point. Variations are more smoothly corrected but an offset will occur (between set and achieved temperatures) as conditions vary.

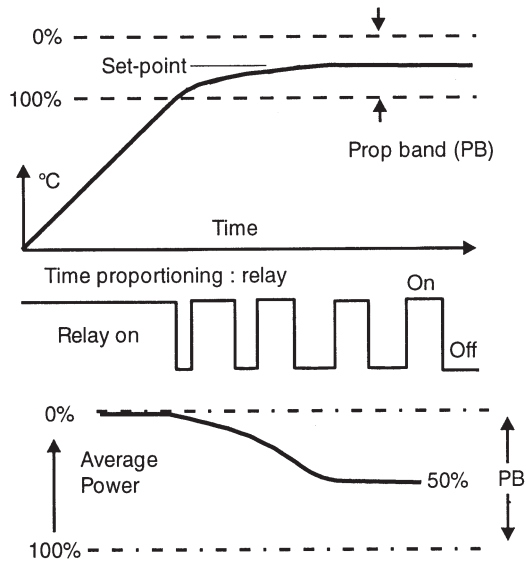

Fig 53: Proportional Control

Average heater power over a period of time is regulated and applied power is proportional to the error between sensor temperature and set-point (usually by time proportioning relay switching). The region over which power is thus varied is called the Proportional Band (PB) it is usually defined as a percentage of full scale.

- c) **Integral (Offset)** I is the deviation of the sensor temperature from the desired value (set-point). This can be adjusted out manually by means of a potentiometer adjustment (Manual Reset) or automatically (Integral Action).

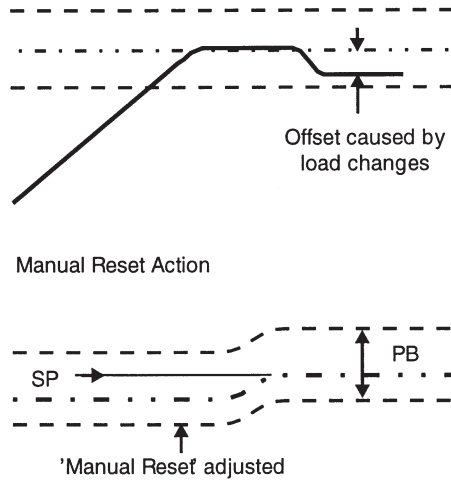

Fig 54: Offset

- d) **Proportional + Derivative (PD)** – The Derivative term when combined with proportional action improves control by sensing changes and correcting for them quickly. The proportional action is effectively intensified (its gain is increased) to achieve a quicker response.

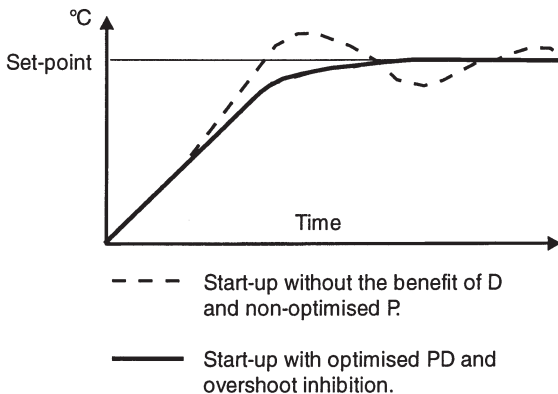

Fig 55: Start-up Performance with PD Control

PD action is commonly employed in general applications. Its use can minimise or even eliminate overshoot on system start up.

e) **Proportional + Integral + Derivative (PID)**

Adding an integral term to PD control can provide automatic and continuous elimination of any offset. Integral action operates in the steady state condition by shifting the Proportional Band upscale or downscale until the system temperature and set-point coincide.

f) **Approach Optimisation**

Under certain conditions, even with PID action, when the process is started, the set-point value can be exceeded prior to the process settling down and this is referred to as “start-up overshoot”. Many controllers employ certain techniques to minimize this situation; this is referred to as “approach optimization”

g) **Choosing P, PD or PID**

Although superior control can be achieved in many cases with PID control action, values of the PID terms inappropriate to the application can cause problems.

If an adequately powered system with good thermal response exists and the best possible control accuracy is required, full PID control is recommended.

If somewhat less critical precision is demanded, the simpler PD action will suffice and will suit a broad range of applications.

If simple control is all that is required, for instance to improve upon thermostatic switching, Proportional (P) or on-off action will suffice.

Adjustable PID Values?

If the controller specified offers adjustable PID values, the opportunity exists to optimise or “tune” the control loop to achieve the best possible accuracy in each case.

Fuzzy Logic

Fuzzy logic is a development of computer intelligence which, when utilized in controllers allows them to handle a diverse range of system demands. Basically, the controller benefits from optimization techniques which learn the process characteristics.

Benefits include a more rapid start up with little or no overshoot, more rapid settling following process disturbances (e.g. opening an oven door) and changes in set-point.

Heating and Cooling

Controllers which are used in processes requiring both heating and cooling use a heat-cool algorithm to achieve a stable temperature in the “cross-over region” (a heating-cooling overlap). Such applications include exothermic conditions where resultant work (process generated) heat could result in excessive temperature (e.g. plastics extruder barrels).

Typically, the heating would be electrical and the cooling achieved by water or fan.

8.3. OPTIMISING CONTROL TERMS (TUNING)

The majority of modern controller and control systems utilize self-tuning circuitry for automatic loop optimization. Where manually adjusted PID values are used the "Fast Tune" guide below is useful.

Fast Tune PID Control

All processes have some finite delays and on-off control will result in start-up temperature overshoot as shown.

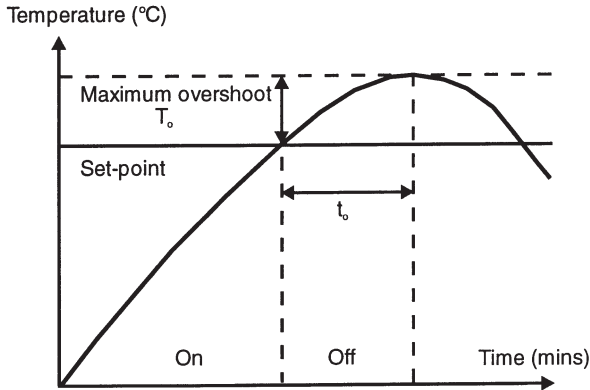

Fig 56: Start-up Temperature Overshoot

Firstly adjust P to minimum, D to off and I to off (or some very large value if not to off).

Full power is applied to the heaters and is switched off when the measured temperature rises to set-point. The resultant overshoot T_o and the time taken to attain the maximum overshoot t_o , allow suitable P, I and D values to be calculated:

$$P = \frac{\text{overshoot } ^\circ\text{C } (T_o)}{\text{controller span, } ^\circ\text{C}} \times 100 \quad \text{percent}$$

$$D = \frac{120t_o}{5} \quad \text{seconds}$$

$$I = 4 t_o \quad \text{minutes}$$

These or similar values should then be set on the controller and good results will be achieved.

For critical processes there are alternative more precise methods for obtaining optimum PID values. Such methods are more time consuming and Auto Tune Techniques described below provide an attractive solution in most applications, simple or complex.

Auto Tune PID Control

Auto tune controllers utilize PID terms and an “approach” feature which are all optimized automatically. During the first process warm-up the controller familiarizes itself with the system dynamics and performs self-optimisation. No user adjustments are required for PID values. Some instruments include an “approach” feature to minimize or eliminate start-up overshoot, also automatically.

8.4. CONTROL OUTPUTS & ALARMS

Accurate and reliable energy regulation are essential for good control loop performance if it is assumed that suitable PID values have been determined and applied.

Depending on the method of applying energy to the process, for example electrical energy to a resistive heating element, a suitable type of controller output arrangement must be specified. In some cases, more than one output may be required (e.g. for multi-zone heaters, heating-cooling applications).

Options most commonly available are:

Electromagnetic Relay, typically rated 2,5 or 10 Ampere contact.

Electronic relay (Solid State Relay or SSR) typically rated up to 3kW.

Thyristor Unit, usually rated from 3kW to 100kW.

Analogue dc control signals, usually 0-1V, 1-5V, 4-20mA and similar to operate external energy regulation devices or converters (e.g. external thyristor units).

Valve Positioner, actuator drive for gas or oil fired burners with or without position feedback function.

Alarms and safety

Whilst built-in alarms provide a convenient method of “policing” the process against over or under temperature occurrence, they should never be relied upon for plant safety. If there is any possibility that component or sensor failure could result in heating power being permanently applied instead of regulated then a completely independent over-temperature alarm should be utilized. In the event of excessive temperature rise, such an alarm would remove energy from the process.

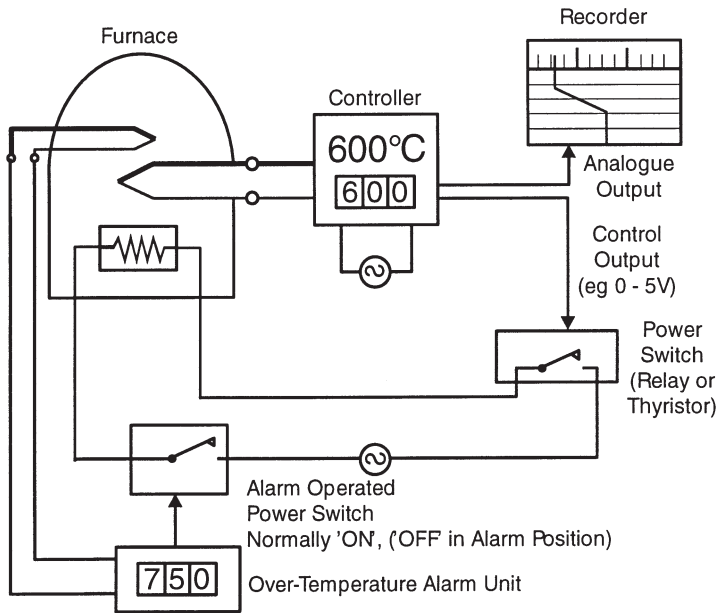

Fig 57: Temperature Control System with Independent Alarm

Alarm Functions

1. High Alarm – this operates if the process temperature exceeds the alarm set value.
2. Low Alarm – this operates if the process temperature falls below the alarm set value
3. High / Low Alarm – this operates if the process temperature exceeds or falls below the alarm set values.
4. Deviation Alarm – this operates if the process temperature reaches a pre-determined deviation from the set-point.
5. Process Alarm – this operates if the process temperature reaches the alarm set value, regardless of the process set-point value.

In practice, various features are available with alarm functions to suit process needs. These include dead-band, delay and reset functions and alternative contact modes.

9. REFERENCE SECTION

This chapter comprises four parts:

- 9.1 Reference data on thermocouple thermometry
- 9.2 Reference data on Platinum resistance thermometry
- 9.3 Thermocouple and Pt100 characteristics
- 9.4 General thermometry data and other reference information

Colour codes for thermocouple wire and cable insulations are shown on page 139

9.1 THERMOCOUPLE THERMOMETRY

9.1.1. Thermocouple Accuracies

Tolerance classes for thermocouples to IEC 584-2 : 1982.

Fe-Con (J)	Class 1	- 40 +750°C:	$\pm 0.004 \cdot t$	or $\pm 1.5^{\circ}\text{C}$
	Class 2	- 40 +750°C:	$\pm 0.0075 \cdot t$	or $\pm 2.5^{\circ}\text{C}$
	Class 3	- - -	-	
Cu-Con (T)	Class 1	- 40 +350°C:	$\pm 0.004 \cdot t$	or $\pm 0.5^{\circ}\text{C}$
	Class 2	- 40 +350°C:	$\pm 0.0075 \cdot t$	or $\pm 1.0^{\circ}\text{C}$
	Class 3	-200 + 40°C:	$\pm 0.015 \cdot t$	or $\pm 1.0^{\circ}\text{C}$
NiCr -Ni (K) and NiCrSi-NiSi (N)	Class 1	- 40 +1000°C:	$\pm 0.004 \cdot t$	or $\pm 1.5^{\circ}\text{C}$
	Class 2	- 40 +1200°C:	$\pm 0.0075 \cdot t$	or $\pm 2.5^{\circ}\text{C}$
	Class 3	-200 + 40°C:	$\pm 0.015 \cdot t$	or $\pm 2.5^{\circ}\text{C}$
NiCr-Con (E)	Class 1	- 40 +800°C:	$\pm 0.004 \cdot t$	or $\pm 1.5^{\circ}\text{C}$
	Class 2	- 40 +900°C:	$\pm 0.0075 \cdot t$	or $\pm 2.5^{\circ}\text{C}$
	Class 3	-200 + 40°C:	$\pm 0.015 \cdot t$	or $\pm 2.5^{\circ}\text{C}$
Pt10Rh-Pt (S) and Pt13Rh-Pt (R)	Class 1	0 +1600°C:	$\pm [1+(t-1000) \cdot 0.003]$	or $\pm 1.0^{\circ}\text{C}$
	Class 2	- 40 +1600°C:	$\pm 0.0025 \cdot t$	or $\pm 1.5^{\circ}\text{C}$
	Class 3	- - -	-	
Pt30Rh- Pt6Rh (B)	Class 1	- - -	-	
	Class 2	+600 +1700°C:	$\pm 0.0025 \cdot t$	or $\pm 1.5^{\circ}\text{C}$
	Class 3	+600 +1700°C:	$\pm 0.005 \cdot t$	or $\pm 4.0^{\circ}\text{C}$

Note: t = actual temperature

Use the larger of the two deviation values

9.1.2. Base Metal Extension and Compensating Wires and Cable Types and Tolerances

Thermocouple Wire Types and Codes IEC 584-3 : 1989

Thermocouple Type	Conductors +/-	Cable Code
E	Nickel Chromium/Constantan (Nickel Chromium/Copper-Nickel, Chromel/Constantan, T1/Advance, NiCr/Constantan)	EX
J	Iron*/Constantan (Iron/Copper-Nickel, Fe/Konst, Iron/Advance, Fe/Constantan, I/C)	JX
K	Nickel Chromium/Nickel Aluminium* (NC/NA, Chromel/Alumel, C/A, T1/T2 NiCr/Ni, NiCr/NiAl)	KX
N	Nicrosil/Nisil	NX NC
T	Copper/Constantan (Copper/Copper-Nickel, Cu/Con, Copper/Advance)	TX
Vx	Copper/Constantan (Low Nickel) (Cu/Constantan) Compensating for "K" (Cu/Constantan)	KCB
U	Copper/Copper Nickel, Compensating for Platinum 10% or 13% Rhodium/Platinum (Codes S and R respectively) Copper/Cupronic, Cu/CuNi, Copper/No.11 Alloy)	RCA SCA

*Magnetic () Alternative & Trade Names

Identification as to whether a thermocouple cable type is extension or compensating is indicated in the example which follows; however, please note that a letter A or B after the C for Compensating refers to the Cable Temperature Range in accordance with the Table of Tolerance Values set out in this standard.

K X 1 = K EXTENSION CLASS 1

K CA 2 = K COMPENSATING CLASS 2 0 to 150°

For further information please refer to the publication BS4937 Part 30.

Table of Thermocouple Wire Tolerances

The figures shown in the tables are those appropriate to the measuring junction temperatures in the final column. In most cases the error expressed in degrees celcius will be larger at lower thermocouple junction temperatures.

Type	Tolerance Class		Cable Temperature range	Measuring junction temperature
	1	2		
JX	$\pm 85\mu V(\pm 1.5^{\circ}C)$	$\pm 140\mu V(\pm 2.5^{\circ}C)$	-25°C to +200°C	500°C
TX	$\pm 30\mu V(\pm 0.5^{\circ}C)$	$\pm 60\mu V(\pm 1.0^{\circ}C)$	-25°C to +100°C	300°C
EX	$\pm 120\mu V(\pm 1.5^{\circ}C)$	$\pm 200\mu V(\pm 2.5^{\circ}C)$	-25°C to +200°C	500°C
KX	$\pm 60\mu V(\pm 1.5^{\circ}C)$	$\pm 100\mu V(\pm 2.5^{\circ}C)$	-25°C to +200°C	900°C
NX	$\pm 60\mu V(\pm 1.5^{\circ}C)$	$\pm 100\mu V(\pm 2.5^{\circ}C)$	-25°C to +200°C	900°C
KCA	-	$\pm 100\mu V(\pm 2.5^{\circ}C)$	0°C to +150°C	900°C
KCB	-	$\pm 100\mu V(\pm 2.5^{\circ}C)$	0°C to +100°C	900°C
NC	-	$\pm 100\mu V(\pm 2.5^{\circ}C)$	0°C to +150°C	900°C
RCA	-	$\pm 30\mu V(\pm 2.5^{\circ}C)$	0°C to +100°C	1000°C
RCB	-	$\pm 60\mu V(\pm 5.0^{\circ}C)$	0°C to +200°C	1000°C
SCA	-	$\pm 30\mu V(\pm 2.5^{\circ}C)$	0°C to +100°C	1000°C
SCB	-	$\pm 60\mu V(\pm 5.0^{\circ}C)$	0°C to +200°C	1000°C

Notes:

1. Cable temperature range may be restricted to figures lower than those shown in the table because of temperature limitations imposed by the insulant.
2. A cable comprising two copper conductors may be used with type B thermocouples. The expected maximum additional deviation within the cable temperature range 0°C to +100°C is 40μV. The equivalent in temperature is 3.5°C when the measuring junction of the thermocouple is at 1400°C.

9.1.3. Wire and Cable Data

Thermocouple Wire

Twin, single conductor, having a temperature / e.m.f. relationship to the appropriate standard over the complete temperature range.

Extension Cable

Twin, stranded conductors for connection between measuring thermocouple and instrument (or external reference junction) of the same materials as the thermocouple and having the same e.m.f. / temperature characteristics over a temperature range limited by the insulation material.

Compensating Wire or Cable

Twin, single or standard conductors for connection between measuring thermocouple and instrument (or external reference junction) of different composition from the thermocouple material, but having similar e.m.f / temperature characteristics over a limited temperature range. Types U and Vx in Conductors Table.

Connection of Themocouples to Measuring Instruments

Ordinary copper wires should never be used, as the error will be equal to the difERENCE in temperature between the connecting point of the thermocouple and the instrument (or external reference junction).

Extension or compensating wire or cable must be employed, and it is essential that the same polarity is maintained. If the polarity is reversed, the error is equal to twice the temperature difference between the connecting point of the thermocouple and the instrument (or external reference junction). For maximum accuracy extension cables should be used, and the terminals and connectors should be of thermocouple materials to maintain continuity.

Single / Multi-strand

The choice is mainly determined by the application (e.g. termination considerations and internal diameter of associated sheath). Generally, single strand wires are used for hot junctions, and multistrand for extensions of the thermocouple as being more flexible. The greater the effective conductor diameter, the lower the value of thermocouple loop resistance; an important consideration with long cable runs.

Conductor Size Equivalents (diameter)

No.	SWG		B&S (AWG)		No.	SWG		B&S(AWG)	
	inches	mm	inches	mm		inches	mm	inches	mm
0	0.324	8.23	0.3249	8.25	26	0.018	0.457	0.0159	0.404
1	0.300	7.62	0.2893	7.35	27	0.0164	0.417	0.0142	0.361
2	0.276	7.01	0.2576	6.54	28	0.0148	0.376	0.0126	0.320
3	0.252	6.40	0.2294	5.83	29	0.0136	0.345	0.0113	0.287
4	0.232	5.89	0.2043	5.19	30	0.0124	0.315	0.0100	0.254
5	0.212	5.38	0.1819	4.62	31	0.0116	0.295	0.0089	0.226
6	0.192	4.88	0.1620	4.11	32	0.0108	0.274	0.0080	0.203
7	0.176	4.47	0.1443	3.67	33	0.0100	0.254	0.0071	0.180
8	0.160	4.06	0.1285	3.26	34	0.0092	0.234	0.0063	0.160
9	0.144	3.66	0.1144	2.91	35	0.0084	0.213	0.0056	0.142
10	0.128	3.25	0.1019	2.59	36	0.0076	0.193	0.0050	0.127
11	0.116	2.95	0.0907	2.30	37	0.0068	0.173	0.0045	0.114
12	0.104	2.64	0.0808	2.05	38	0.0060	0.152	0.0040	0.102
13	0.092	2.34	0.0720	1.83	39	0.0052	0.132	0.0035	0.089
14	0.080	2.03	0.0641	1.63	40	0.0048	0.122	0.0031	0.079
15	0.072	1.83	0.0571	1.45	41	0.0044	0.112	0.0028	0.071
16	0.064	1.63	0.0508	1.29	42	0.0040	0.102	0.0025	0.064
17	0.056	1.42	0.0453	1.15	43	0.0036	0.091	0.0022	0.056
18	0.048	1.22	0.0403	1.02	44	0.0032	0.081	0.0020	0.051
19	0.040	1.02	0.0359	0.912	45	0.0028	0.071	0.0018	0.046
20	0.036	0.914	0.0320	0.813	46	0.0024	0.061	-	-
21	0.032	0.813	0.0285	0.724	47	0.0020	0.051	-	-
22	0.028	0.711	0.0253	0.643	48	0.0016	0.041	-	-
23	0.024	0.610	0.0226	0.574	49	0.0012	0.030	-	-
24	0.022	0.559	0.0201	0.511	50	0.0010	0.025	-	-
25	0.020	0.508	0.0179	0.455					

SWG = (BRITISH) STANDARD WIRE GAUGE

B&S = BROWN AND SHARPE

AWG = AMERICAN WIRE GAUGE

Conductor Cross Sectional Areas

Metric	mm ²	SWG	AWG	Single Strand	
				dia. inches	dia. mm
1/0.2	0.032	-	32	0.0080	0.20
1/0.315	0.078	30	-	0.0124	0.31
1/0.508	0.203	25	-	0.0200	0.51
7/0.2	0.219	-	-	0.0206	0.52
14/0.2	0.412	-	21	0.0285	0.72

Insulated Wire Sizes (Subject to variation)

Sizes in mm

Insulation	Wire Size Insulated Conductor	Each Sheath	Overall
PVC			
Figure of 8	1/0.508	-	1.4 x 2.7
Flat Pair	7/0.2	1.7	3.4 x 4.8
Flat Pair	13/0.2	1.9	3.4 x 5.1
Flat Pair	23/0.2	2.0	3.5 x 5.5
PTFE			
Twisted Pair	1/0.2	0.6	
Twisted Pair	1/0.315	0.7	
Twisted Pair	1/0.508	0.8	
Flat Pair	1/0.315	0.6	1.3 x 1.9
Flat Pair	7/0.2	0.9	5.5 x 2.4
GLASSFIBRE			
Flat Pair	1/0.2	0.5	1.0 x 1.4
Flat Pair	1/0.315	0.7	1.1 x 1.7
Flat Pair	1/0.508	0.8	1.3 x 2.0
Flat Pair	7/0.2	0.8	1.1 x 1.9
Flat Pair	14/0.2	1.0	1.3 x 2.2
GLASSFIBRE & S.S. OVERBRAID			
	7/0.2	0.9	1.6 x 2.4

Code	1/0.2	1/0.315	1/0.508	7/0.2	13/0.2	14/0.2	23/0.2
E	38.1	15.4	5.9	5.3	2.9	2.7	1.6
J	19.3	7.8	3.0	2.7	1.5	1.4	0.8
K	31.8	12.8	4.9	4.5	2.4	2.2	1.4
N	44.2	17.7	6.8	6.2	3.4	3.2	1.9
T	16.2	6.5	2.5	2.3	1.2	1.1	0.7
U	1.4	0.6	0.2	0.2	0.1	0.1	0.1
VX	16.2	6.5	2.5	2.3	1.2	1.1	0.7

9.2 PLATINUM RESISTANCE THERMOMETRY

9.2.1. Tolerances for Pt100 Thermometers to IEC 751 : 1983

Temp (°C)	Resistance (Ω)	Tolerance			
		Class A (±°C)	(±Ω)	Class B (±°C)	(±Ω)
-200	18.52	0.55	0.24	1.3	0.56
-100	60.26	0.35	0.14	0.8	0.32
0	100.00	0.15	0.06	0.3	0.12
100	138.51	0.35	0.13	0.8	0.30
200	175.86	0.55	0.20	1.3	0.48
300	212.05	0.75	0.27	1.8	0.64
400	247.09	0.95	0.33	2.3	0.79
500	280.98	1.15	0.38	2.8	0.93
600	313.71	1.35	0.43	3.3	1.06
650	329.64	1.45	0.46	3.6	1.13
700	345.28	–	–	3.8	1.17
800	375.70	–	–	4.3	1.28
850	390.48	–	–	4.6	1.34

9.2.2. Connection Configurations and Termination Colour Codes IEC 751 : 1983

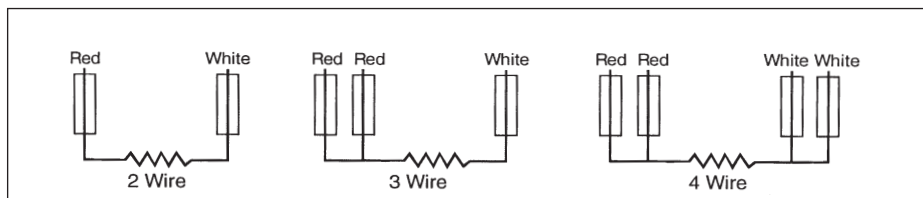

9.3 THERMOCOUPLE AND PT100 CHARACTERISTICS

9.3.1. Pt100 Characteristics IEC 751 : 1983

Industrial Platinum Resistance Thermometer Sensors

$$R(0) = 100.00\Omega$$

°C ITS 90	0	1	2	3	4	5	6	7	8	9	10	°C ITS 90
-200	18.52											-200
-190	22.83	22.40	21.97	21.54	21.11	20.68	20.25	19.82	19.38	18.95	18.52	-190
-180	27.10	26.67	26.24	25.82	25.39	24.97	24.54	24.11	23.68	23.25	22.83	-180
-170	31.34	30.91	30.49	30.07	29.64	29.22	28.80	28.37	27.95	27.52	27.10	-170
-160	35.54	35.12	34.70	34.28	33.86	33.44	33.02	32.60	32.18	31.76	31.34	-160
-150	39.72	39.31	38.89	38.47	38.05	37.64	37.22	36.80	36.38	35.96	35.54	-150
-140	43.88	43.46	43.05	42.63	42.22	41.80	41.39	40.97	40.56	40.14	39.72	-140
-130	48.00	47.59	47.18	46.77	46.36	45.94	45.53	45.12	44.70	44.29	43.88	-130
-120	52.11	51.70	51.29	50.88	50.47	50.06	49.65	49.24	48.83	48.42	48.00	-120
-110	56.19	55.79	55.38	54.97	54.56	54.15	53.75	53.34	52.93	52.52	52.11	-110
-100	60.26	59.85	59.44	59.04	58.63	58.23	57.82	57.41	57.01	56.60	56.19	-100
-90	64.30	63.90	63.49	63.09	62.68	62.28	61.88	61.47	61.07	60.66	60.26	-90
-80	68.33	67.92	67.52	67.12	66.72	66.31	65.91	65.51	65.11	64.70	64.30	-80
-70	72.33	71.93	71.53	71.13	70.73	70.33	69.93	69.53	69.13	68.73	68.33	-70
-60	76.33	75.93	75.53	75.13	74.73	74.33	73.93	73.53	73.13	72.73	72.33	-60
-50	80.31	79.91	79.51	79.11	78.72	78.32	77.92	77.52	77.12	76.73	76.33	-50
-40	84.27	83.87	83.48	83.08	82.69	82.29	81.89	81.50	81.10	80.70	80.31	-40
-30	88.22	87.83	87.43	87.04	86.64	86.25	85.85	85.46	85.06	84.67	84.27	-30
-20	92.16	91.77	91.37	90.98	90.59	90.19	89.80	89.40	89.01	88.62	88.22	-20
-10	96.09	95.69	95.30	94.91	94.52	94.12	93.73	93.34	92.95	92.55	92.16	-10
0	100.00	99.61	99.22	98.83	98.44	98.04	97.65	97.26	96.87	96.48	96.09	0
10	103.90	103.51	103.12	102.73	102.34	101.95	101.56	101.17	100.78	100.39	100.00	10
20	107.79	107.40	107.01	106.62	106.23	105.84	105.45	105.06	104.67	104.28	103.89	20
30	111.67	111.28	110.89	110.50	110.11	109.72	109.33	108.94	108.55	108.16	107.77	30
40	115.54	115.15	114.76	114.37	113.98	113.59	113.20	112.81	112.42	112.03	111.64	40
50	119.40	119.01	118.62	118.23	117.84	117.45	117.06	116.67	116.28	115.89	115.50	50
60	123.24	122.85	122.46	122.07	121.68	121.29	120.90	120.51	120.12	119.73	119.34	60
70	127.08	126.69	126.30	125.91	125.52	125.13	124.74	124.35	123.96	123.57	123.18	70
80	130.90	130.51	130.12	129.73	129.34	128.95	128.56	128.17	127.78	127.39	127.00	80
90	134.71	134.32	133.93	133.54	133.15	132.76	132.37	131.98	131.59	131.20	130.81	90
100	138.51	138.12	137.73	137.34	136.95	136.56	136.17	135.78	135.39	135.00	134.61	100
110	142.29	141.90	141.51	141.12	140.73	140.34	139.95	139.56	139.17	138.78	138.39	110
120	146.07	145.68	145.29	144.90	144.51	144.12	143.73	143.34	142.95	142.56	142.17	120
130	149.83	149.44	149.05	148.66	148.27	147.88	147.49	147.10	146.71	146.32	145.93	130
140	153.58	153.19	152.80	152.41	152.02	151.63	151.24	150.85	150.46	150.07	149.68	140
150	157.33	156.94	156.55	156.16	155.77	155.38	154.99	154.60	154.21	153.82	153.43	150
160	161.05	160.66	160.27	159.88	159.49	159.10	158.71	158.32	157.93	157.54	157.15	160
170	164.77	164.38	163.99	163.60	163.21	162.82	162.43	162.04	161.65	161.26	160.87	170
180	168.48	168.09	167.70	167.31	166.92	166.53	166.14	165.75	165.36	164.97	164.58	180
190	172.17	171.78	171.39	171.00	170.61	170.22	169.83	169.44	169.05	168.66	168.27	190
200	175.86	175.47	175.08	174.69	174.30	173.91	173.52	173.13	172.74	172.35	171.96	200
210	179.53	179.14	178.75	178.36	177.97	177.58	177.19	176.80	176.41	176.02	175.63	210
220	183.19	182.80	182.41	182.02	181.63	181.24	180.85	180.46	180.07	179.68	179.29	220
230	186.84	186.45	186.06	185.67	185.28	184.89	184.50	184.11	183.72	183.33	182.94	230
240	190.47	190.08	189.69	189.30	188.91	188.52	188.13	187.74	187.35	186.96	186.57	240
250	194.10	193.71	193.32	192.93	192.54	192.15	191.76	191.37	190.98	190.59	190.20	250
260	197.71	197.32	196.93	196.54	196.15	195.76	195.37	194.98	194.59	194.20	193.81	260
270	201.31	200.92	200.53	200.14	199.75	199.36	198.97	198.58	198.19	197.80	197.41	270
280	204.90	204.51	204.12	203.73	203.34	202.95	202.56	202.17	201.78	201.39	201.00	280
290	208.48	208.09	207.70	207.31	206.92	206.53	206.14	205.75	205.36	204.97	204.58	290
300	212.05	211.66	211.27	210.88	210.49	210.10	209.71	209.32	208.93	208.54	208.15	300
310	215.61	215.22	214.83	214.44	214.05	213.66	213.27	212.88	212.49	212.10	211.71	310
320	219.15	218.76	218.37	217.98	217.59	217.20	216.81	216.42	216.03	215.64	215.25	320
330	222.68	222.29	221.90	221.51	221.12	220.73	220.34	219.95	219.56	219.17	218.78	330
340	226.21	225.82	225.43	225.04	224.65	224.26	223.87	223.48	223.09	222.70	222.31	340

Industrial Platinum Resistance Thermometer Sensors

R(0) = 100.00Ω

°C ITS 90	0	1	2	3	4	5	6	7	8	9	10	°C ITS 90
350	229.72	230.07	230.42	230.77	231.12	231.47	231.82	232.17	232.52	232.87	233.21	350
360	233.21	233.56	233.91	234.26	234.61	234.96	235.31	235.66	236.00	236.35	236.70	360
370	236.70	237.05	237.40	237.74	238.09	238.44	238.79	239.13	239.48	239.83	240.18	370
380	240.18	240.52	240.87	241.22	241.56	241.91	242.26	242.60	242.95	243.29	243.64	380
390	243.64	243.99	244.33	244.68	245.02	245.37	245.71	246.06	246.40	246.75	247.09	390
400	247.09	247.44	247.78	248.13	248.47	248.81	249.16	249.50	249.85	250.19	250.53	400
410	250.53	250.88	251.22	251.56	251.91	252.25	252.59	252.93	253.28	253.62	253.96	410
420	253.96	254.30	254.65	254.99	255.33	255.67	256.01	256.35	256.70	257.04	257.38	420
430	257.38	257.72	258.06	258.40	258.74	259.08	259.42	259.76	260.10	260.44	260.78	430
440	260.78	261.12	261.46	261.80	262.14	262.48	262.82	263.16	263.50	263.84	264.18	440
450	264.18	264.52	264.86	265.20	265.53	265.87	266.21	266.55	266.89	267.22	267.56	450
460	267.56	267.90	268.24	268.57	268.91	269.25	269.59	269.92	270.26	270.60	270.93	460
470	270.93	271.27	271.61	271.94	272.28	272.61	272.95	273.29	273.62	273.96	274.29	470
480	274.29	274.63	274.96	275.30	275.63	275.97	276.30	276.64	276.97	277.31	277.64	480
490	277.64	277.98	278.31	278.64	278.98	279.31	279.64	279.98	280.31	280.64	280.98	490
500	280.98	281.31	281.64	281.98	282.31	282.64	282.97	283.31	283.64	283.97	284.30	500
510	284.30	284.63	284.97	285.30	285.63	285.96	286.29	286.62	286.95	287.29	287.62	510
520	287.62	287.95	288.28	288.61	288.94	289.27	289.60	289.93	290.26	290.59	290.92	520
530	290.92	291.25	291.58	291.91	292.24	292.56	292.89	293.22	293.55	293.88	294.21	530
540	294.21	294.54	294.86	295.19	295.52	295.85	296.18	296.50	296.83	297.16	297.49	540
550	297.49	297.81	298.14	298.47	298.80	299.12	299.45	299.78	300.10	300.43	300.75	550
560	300.75	301.08	301.41	301.73	302.06	302.38	302.71	303.03	303.36	303.69	304.01	560
570	304.01	304.34	304.66	304.98	305.31	305.63	305.96	306.28	306.61	306.93	307.25	570
580	307.25	307.58	307.90	308.23	308.55	308.87	309.20	309.52	309.84	310.16	310.49	580
590	310.49	310.81	311.13	311.45	311.78	312.10	312.42	312.74	313.06	313.39	313.71	590
600	313.71	314.03	314.35	314.67	314.99	315.31	315.64	315.96	316.28	316.60	316.92	600
610	316.92	317.24	317.56	317.88	318.20	318.52	318.84	319.16	319.48	319.80	320.12	610
620	320.12	320.44	320.76	321.08	321.40	321.72	322.04	322.36	322.68	322.99	323.30	620
630	323.30	323.62	323.94	324.26	324.57	324.89	325.21	325.53	325.84	326.16	326.48	630
640	326.48	326.79	327.11	327.43	327.74	328.06	328.38	328.69	329.01	329.32	329.64	640
650	329.64	329.96	330.27	330.59	330.90	331.22	331.53	331.85	332.16	332.48	332.79	650
660	332.79	333.11	333.42	333.74	334.05	334.36	334.68	334.99	335.31	335.62	335.93	660
670	335.93	336.25	336.56	336.87	337.18	337.50	337.81	338.12	338.44	338.75	339.06	670
680	339.06	339.37	339.69	340.00	340.31	340.62	340.93	341.24	341.56	341.87	342.18	680
690	342.18	342.49	342.80	343.11	343.42	343.73	344.04	344.35	344.66	344.97	345.28	690
700	345.28	345.59	345.90	346.21	346.52	346.83	347.14	347.45	347.76	348.07	348.38	700
710	348.38	348.69	348.99	349.30	349.61	349.92	350.23	350.54	350.84	351.15	351.46	710
720	351.46	351.77	352.08	352.38	352.69	353.00	353.30	353.61	353.92	354.22	354.53	720
730	354.53	354.84	355.14	355.45	355.76	356.06	356.37	356.67	356.98	357.28	357.59	730
740	357.59	357.90	358.20	358.51	358.81	359.12	359.42	359.72	360.03	360.33	360.64	740
750	360.64	360.94	361.25	361.55	361.85	362.16	362.46	362.76	363.07	363.37	363.67	750
760	363.67	363.98	364.28	364.58	364.89	365.19	365.49	365.79	366.10	366.40	366.70	760
770	366.70	367.00	367.30	367.60	367.91	368.21	368.51	368.81	369.11	369.41	369.71	770
780	369.71	370.01	370.31	370.61	370.91	371.21	371.51	371.81	372.11	372.41	372.71	780
790	372.71	373.01	373.31	373.61	373.91	374.21	374.51	374.81	375.11	375.41	375.70	790
800	375.70	376.00	376.30	376.60	376.90	377.19	377.49	377.79	378.09	378.39	378.68	800
810	378.68	378.98	379.28	379.57	379.87	380.17	380.46	380.76	381.06	381.35	381.65	810
820	381.65	381.95	382.24	382.54	382.83	383.13	383.42	383.72	384.01	384.31	384.60	820
830	384.60	384.90	385.19	385.49	385.78	386.08	386.37	386.67	386.96	387.25	387.55	830
840	387.55	387.84	388.14	388.43	388.72	389.02	389.31	389.60	389.90	390.19	390.48	840
850	390.48											850

9.3.2. Thermocouple Characteristics IEC 584-1:1995

Type S Thermocouple Table

Platinum – 10% Rhodium/Platinum, Electromotive force as a function of temperature

		E/ μ V										
190/°C	0	1	2	3	4	5	6	7	8	9	190/°C	
0	0	5	11	16	22	27	33	38	44	50	0	
10	55	61	67	72	78	84	90	95	101	107	10	
20	113	119	125	131	137	143	149	155	161	167	20	
30	173	179	185	191	197	204	210	216	222	229	30	
40	235	241	248	254	260	267	273	280	286	292	40	
50	299	305	312	319	325	332	338	345	352	358	50	
60	365	372	378	385	392	399	405	412	419	426	60	
70	433	440	446	453	460	467	474	481	488	495	70	
80	502	509	516	523	530	538	545	552	559	566	80	
90	573	580	588	595	602	609	617	624	631	639	90	
100	646	653	661	668	675	683	690	698	705	713	100	
110	720	727	735	743	750	758	765	773	780	788	110	
120	795	803	811	818	826	834	841	849	857	865	120	
130	872	880	888	896	903	911	919	927	935	942	130	
140	950	958	966	974	982	990	998	1006	1013	1021	140	
150	1029	1037	1045	1053	1061	1069	1077	1085	1094	1102	150	
160	1110	1118	1126	1134	1142	1150	1158	1167	1175	1183	160	
170	1191	1199	1207	1216	1224	1232	1240	1249	1257	1265	170	
180	1273	1282	1290	1298	1307	1315	1323	1332	1340	1348	180	
190	1357	1365	1373	1382	1390	1399	1407	1415	1424	1432	190	
200	1441	1449	1458	1466	1475	1483	1492	1500	1509	1517	200	
210	1526	1534	1543	1551	1560	1569	1577	1586	1594	1603	210	
220	1612	1620	1629	1638	1646	1655	1663	1672	1681	1690	220	
230	1698	1707	1716	1724	1733	1742	1751	1759	1768	1777	230	
240	1786	1794	1803	1812	1821	1829	1838	1847	1856	1865	240	
250	1874	1882	1891	1900	1909	1918	1927	1936	1944	1953	250	
260	1962	1971	1980	1989	1998	2007	2016	2025	2034	2043	260	
270	2052	2061	2070	2078	2087	2096	2105	2114	2123	2132	270	
280	2141	2151	2160	2169	2178	2187	2196	2205	2214	2223	280	
290	2232	2241	2250	2259	2268	2277	2287	2296	2305	2314	290	
300	2323	2332	2341	2350	2360	2369	2378	2387	2396	2405	300	
310	2415	2424	2433	2442	2451	2461	2470	2479	2488	2497	310	
320	2507	2516	2525	2534	2544	2553	2562	2571	2581	2590	320	
330	2599	2609	2618	2627	2636	2646	2655	2664	2674	2683	330	
340	2692	2702	2711	2720	2730	2739	2748	2758	2767	2776	340	
350	2786	2795	2805	2814	2823	2833	2842	2851	2861	2870	350	
360	2880	2889	2899	2908	2917	2927	2936	2946	2955	2965	360	
370	2974	2983	2993	3002	3012	3021	3031	3040	3050	3059	370	
380	3069	3078	3088	3097	3107	3116	3126	3135	3145	3154	380	
390	3164	3173	3183	3192	3202	3212	3221	3231	3240	3250	390	
400	3259	3269	3279	3288	3298	3307	3317	3326	3336	3346	400	
410	3355	3365	3374	3384	3394	3403	3413	3423	3432	3442	410	
420	3451	3461	3471	3480	3490	3500	3509	3519	3529	3538	420	
430	3548	3558	3567	3577	3587	3596	3606	3616	3626	3635	430	
440	3645	3655	3664	3674	3684	3694	3703	3713	3723	3732	440	
450	3742	3752	3762	3771	3781	3791	3801	3810	3820	3830	450	
460	3840	3850	3859	3869	3879	3889	3898	3908	3918	3928	460	
470	3938	3947	3957	3967	3977	3987	3997	4006	4016	4026	470	
480	4036	4046	4056	4065	4075	4085	4095	4105	4115	4125	480	
490	4134	4144	4154	4164	4174	4184	4194	4204	4213	4223	490	
500	4233	4243	4253	4263	4273	4283	4293	4303	4313	4323	500	
510	4332	4342	4352	4362	4372	4382	4392	4402	4412	4422	510	
520	4432	4442	4452	4462	4472	4482	4492	4502	4512	4522	520	
530	4532	4542	4552	4562	4572	4582	4592	4602	4612	4622	530	
540	4632	4642	4652	4662	4672	4682	4692	4702	4712	4722	540	
550	4732	4742	4752	4762	4772	4782	4793	4803	4813	4823	550	
560	4833	4843	4853	4863	4873	4883	4893	4904	4914	4924	560	
570	4934	4944	4954	4964	4974	4984	4995	5005	5015	5025	570	
580	5035	5045	5055	5066	5076	5086	5096	5106	5116	5127	580	
590	5137	5147	5157	5167	5178	5188	5198	5208	5218	5228	590	

Type S Thermocouple Table

Platinum – 10% Rhodium/Platinum, Electromotive force as a function of temperature

		E/ μ V									
t/90/°C	0	1	2	3	4	5	6	7	8	9	t/90/°C
600	5239	5249	5259	5269	5280	5290	5300	5310	5320	5331	600
610	5341	5351	5361	5372	5382	5392	5402	5413	5423	5433	610
620	5443	5454	5464	5474	5485	5495	5505	5515	5526	5536	620
630	5546	5557	5567	5577	5588	5598	5608	5618	5629	5639	630
640	5649	5660	5670	5680	5691	5701	5712	5722	5732	5743	640
650	5753	5763	5774	5784	5794	5805	5815	5826	5836	5846	650
660	5857	5867	5878	5888	5898	5909	5919	5930	5940	5950	660
670	5961	5971	5982	5992	6003	6013	6024	6034	6044	6055	670
680	6065	6076	6086	6097	6107	6118	6128	6139	6149	6160	680
690	6170	6181	6191	6202	6212	6223	6233	6244	6254	6265	690
700	6275	6286	6296	6307	6317	6328	6338	6349	6360	6370	700
710	6381	6391	6402	6412	6423	6434	6444	6455	6465	6476	710
720	6486	6497	6508	6518	6529	6539	6550	6561	6571	6582	720
730	6593	6603	6614	6624	6635	6646	6656	6667	6678	6688	730
740	6699	6710	6720	6731	6742	6752	6763	6774	6784	6795	740
750	6806	6817	6827	6838	6849	6859	6870	6881	6892	6902	750
760	6913	6924	6934	6945	6956	6967	6977	6988	6999	7010	760
770	7020	7031	7042	7053	7064	7074	7085	7096	7107	7117	770
780	7128	7139	7150	7161	7172	7182	7193	7204	7215	7226	780
790	7236	7247	7258	7269	7280	7291	7302	7312	7323	7334	790
800	7345	7356	7367	7378	7388	7399	7410	7421	7432	7443	800
810	7454	7465	7476	7487	7497	7508	7519	7530	7541	7552	810
820	7563	7574	7585	7596	7607	7618	7629	7640	7651	7662	820
830	7673	7684	7695	7706	7717	7728	7739	7750	7761	7772	830
840	7783	7794	7805	7816	7827	7838	7849	7860	7871	7882	840
850	7893	7904	7915	7926	7937	7948	7959	7970	7981	7992	850
860	8003	8014	8026	8037	8048	8059	8070	8081	8092	8103	860
870	8114	8125	8137	8148	8159	8170	8181	8192	8203	8214	870
880	8226	8237	8248	8259	8270	8281	8293	8304	8315	8326	880
890	8337	8348	8360	8371	8382	8393	8404	8416	8427	8438	890
900	8449	8460	8472	8483	8494	8505	8517	8528	8539	8550	900
910	8562	8573	8584	8595	8607	8618	8629	8640	8652	8663	910
920	8674	8685	8697	8708	8719	8731	8742	8753	8765	8776	920
930	8787	8798	8810	8821	8832	8844	8855	8866	8878	8889	930
940	8900	8912	8923	8935	8946	8957	8969	8980	8991	9003	940
950	9014	9025	9037	9048	9060	9071	9082	9094	9105	9117	950
960	9128	9139	9151	9162	9174	9185	9197	9208	9219	9231	960
970	9242	9254	9265	9277	9288	9300	9311	9323	9334	9345	970
980	9357	9368	9380	9391	9403	9414	9426	9437	9449	9460	980
990	9472	9483	9495	9506	9518	9529	9541	9552	9564	9576	990
1000	9587	9599	9610	9622	9633	9645	9656	9668	9680	9691	1000
1010	9703	9714	9726	9737	9749	9761	9772	9784	9795	9807	1010
1020	9819	9830	9842	9853	9865	9877	9888	9900	9911	9923	1020
1030	9935	9946	9958	9970	9981	9993	10005	10016	10028	10040	1030
1040	10051	10063	10075	10086	10098	10110	10121	10133	10145	10156	1040
1050	10168	10180	10191	10203	10215	10227	10238	10250	10262	10273	1050
1060	10285	10297	10309	10320	10332	10344	10356	10367	10379	10391	1060
1070	10403	10414	10426	10438	10450	10461	10473	10485	10497	10509	1070
1080	10520	10532	10544	10556	10567	10579	10591	10603	10615	10626	1080
1090	10638	10650	10662	10674	10686	10697	10709	10721	10733	10745	1090
1100	10757	10768	10780	10792	10804	10816	10828	10839	10851	10863	1100
1110	10875	10887	10899	10911	10922	10934	10946	10958	10970	10982	1110
1120	10994	11006	11017	11029	11041	11053	11065	11077	11089	11101	1120
1130	11113	11125	11136	11148	11160	11172	11184	11196	11208	11220	1130
1140	11232	11244	11256	11268	11280	11291	11303	11315	11327	11339	1140
1150	11351	11363	11375	11387	11399	11411	11423	11435	11447	11459	1150
1160	11471	11483	11495	11507	11519	11531	11542	11554	11566	11578	1160
1170	11590	11602	11614	11626	11638	11650	11662	11674	11686	11698	1170
1180	11710	11722	11734	11746	11758	11770	11782	11794	11806	11818	1180
1190	11830	11842	11854	11866	11878	11890	11902	11914	11926	11939	1190

Type S Thermocouple Table

Platinum – 10%Rhodium/Platinum, Electromotive force as a function of temperature

t/°C		E/μV									t/°C
0	1	2	3	4	5	6	7	8	9	100	
1200	11951	11963	11975	11987	11999	12011	12023	12035	12047	12059	1200
1210	12071	12083	12095	12107	12119	12131	12143	12155	12167	12179	1210
1220	12191	12203	12216	12228	12240	12252	12264	12276	12288	12300	1220
1230	12312	12324	12336	12348	12360	12372	12384	12397	12409	12421	1230
1240	12433	12445	12457	12469	12481	12493	12505	12517	12529	12542	1240
1250	12554	12566	12578	12590	12602	12614	12626	12638	12650	12662	1250
1260	12675	12687	12699	12711	12723	12735	12747	12759	12771	12783	1260
1270	12796	12808	12820	12832	12844	12856	12868	12880	12892	12905	1270
1280	12917	12929	12941	12953	12965	12977	12989	13001	13014	13026	1280
1290	13038	13050	13062	13074	13086	13098	13111	13123	13135	13147	1290
1300	13159	13171	13183	13195	13208	13220	13232	13244	13256	13268	1300
1310	13280	13292	13305	13317	13329	13341	13353	13365	13377	13390	1310
1320	13402	13414	13426	13438	13450	13462	13474	13487	13499	13511	1320
1330	13523	13535	13547	13559	13572	13584	13596	13608	13620	13632	1330
1340	13644	13657	13669	13681	13693	13705	13717	13729	13742	13754	1340
1350	13766	13778	13790	13802	13814	13826	13839	13851	13863	13875	1350
1360	13887	13899	13911	13924	13936	13948	13960	13972	13984	13996	1360
1370	14009	14021	14033	14045	14057	14069	14081	14094	14106	14118	1370
1380	14130	14142	14154	14166	14178	14191	14203	14215	14227	14239	1380
1390	14251	14263	14276	14288	14300	14312	14324	14336	14348	14360	1390
1400	14373	14385	14397	14409	14421	14433	14445	14457	14470	14482	1400
1410	14494	14506	14518	14530	14542	14554	14567	14579	14591	14603	1410
1420	14615	14627	14639	14651	14664	14676	14688	14700	14712	14724	1420
1430	14736	14748	14760	14773	14785	14797	14809	14821	14833	14845	1430
1440	14857	14869	14881	14894	14906	14918	14930	14942	14954	14966	1440
1450	14978	14990	15002	15015	15027	15039	15051	15063	15075	15087	1450
1460	15099	15111	15123	15135	15148	15160	15172	15184	15196	15208	1460
1470	15220	15232	15244	15256	15268	15280	15292	15304	15317	15329	1470
1480	15341	15353	15365	15377	15389	15401	15413	15425	15437	15449	1480
1490	15461	15473	15485	15497	15509	15521	15534	15546	15558	15570	1490
1500	15582	15594	15606	15618	15630	15642	15654	15666	15678	15690	1500
1510	15702	15714	15726	15738	15750	15762	15774	15786	15798	15810	1510
1520	15822	15834	15846	15858	15870	15882	15894	15906	15918	15930	1520
1530	15942	15954	15966	15978	15990	16002	16014	16026	16038	16050	1530
1540	16062	16074	16086	16098	16110	16122	16134	16146	16158	16170	1540
1550	16182	16194	16206	16218	16229	16241	16253	16265	16277	16289	1550
1560	16301	16313	16325	16337	16349	16361	16373	16385	16397	16408	1560
1570	16420	16432	16444	16456	16468	16480	16492	16504	16516	16527	1570
1580	16539	16551	16563	16575	16587	16599	16611	16623	16634	16646	1580
1590	16658	16670	16682	16694	16706	16718	16729	16741	16753	16765	1590
1600	16777	16789	16801	16812	16824	16836	16848	16860	16872	16883	1600
1610	16895	16907	16919	16931	16943	16954	16966	16978	16990	17002	1610
1620	17013	17025	17037	17049	17061	17072	17084	17096	17108	17120	1620
1630	17131	17143	17155	17167	17178	17190	17202	17214	17225	17237	1630
1640	17249	17261	17272	17284	17296	17308	17319	17331	17343	17355	1640
1650	17366	17378	17390	17401	17413	17425	17437	17448	17460	17472	1650
1660	17483	17495	17507	17518	17530	17542	17553	17565	17577	17588	1660
1670	17600	17612	17623	17635	17647	17658	17670	17682	17693	17705	1670
1680	17717	17728	17740	17751	17763	17775	17786	17798	17809	17821	1680
1690	17832	17844	17855	17867	17878	17890	17901	17913	17924	17936	1690
1700	17947	17959	17970	17982	17993	18004	18016	18027	18039	18050	1700
1710	18061	18073	18084	18095	18107	18118	18129	18140	18152	18163	1710
1720	18174	18185	18196	18208	18219	18230	18241	18252	18263	18274	1720
1730	18285	18297	18308	18319	18330	18341	18352	18362	18373	18384	1730
1740	18395	18406	18417	18428	18439	18449	18460	18471	18482	18493	1740
1750	18503	18514	18525	18535	18546	18557	18567	18578	18588	18599	1750
1760	18609	18620	18630	18641	18651	18661	18672	18682	18693	18700	1760

Type R Thermocouple Table

Platinum – 13% Rhodium/Platinum, Electromotive force as a function of temperature

		E/ μ V										
190/°C	0	1	2	3	4	5	6	7	8	9	190/°C	
0	0	5	11	16	21	27	32	38	43	49	0	
10	54	60	65	71	77	82	88	94	100	105	10	
20	111	117	123	129	135	141	147	153	159	165	20	
30	171	177	183	189	195	201	207	214	220	226	30	
40	232	239	245	251	258	264	271	277	284	290	40	
50	296	303	310	316	323	329	336	343	349	356	50	
60	363	369	376	383	390	397	403	410	417	424	60	
70	431	438	445	452	459	466	473	480	487	494	70	
80	501	508	516	523	530	537	544	552	559	566	80	
90	573	581	588	595	603	610	618	625	632	640	90	
100	647	655	662	670	677	685	693	700	708	715	100	
110	723	731	738	746	754	761	769	777	785	792	110	
120	800	808	816	824	832	839	847	855	863	871	120	
130	879	887	895	903	911	919	927	935	943	951	130	
140	959	967	976	984	992	1000	1008	1016	1025	1033	140	
150	1041	1049	1058	1066	1074	1082	1091	1099	1107	1116	150	
160	1124	1132	1141	1149	1158	1166	1175	1183	1191	1200	160	
170	1208	1217	1225	1234	1242	1251	1260	1268	1277	1285	170	
180	1294	1303	1311	1320	1329	1337	1346	1355	1363	1372	180	
190	1381	1389	1398	1407	1416	1425	1433	1442	1451	1460	190	
200	1469	1477	1486	1495	1504	1513	1522	1531	1540	1549	200	
210	1558	1567	1575	1584	1593	1602	1611	1620	1629	1639	210	
220	1648	1657	1666	1675	1684	1693	1702	1711	1720	1729	220	
230	1739	1748	1757	1766	1775	1784	1794	1803	1812	1821	230	
240	1831	1840	1849	1858	1868	1877	1886	1895	1905	1914	240	
250	1923	1933	1942	1951	1961	1970	1980	1989	1998	2008	250	
260	2017	2027	2036	2046	2055	2064	2074	2083	2093	2102	260	
270	2112	2121	2131	2140	2150	2159	2169	2179	2188	2198	270	
280	2207	2217	2226	2236	2246	2255	2265	2275	2284	2294	280	
290	2304	2313	2323	2333	2342	2352	2362	2371	2381	2391	290	
300	2401	2410	2420	2430	2440	2449	2459	2469	2479	2488	300	
310	2498	2508	2518	2528	2538	2547	2557	2567	2577	2587	310	
320	2597	2607	2617	2626	2636	2646	2656	2666	2676	2686	320	
330	2696	2706	2716	2726	2736	2746	2756	2766	2776	2786	330	
340	2796	2806	2816	2826	2836	2846	2856	2866	2876	2886	340	
350	2896	2906	2916	2926	2937	2947	2957	2967	2977	2987	350	
360	2997	3007	3018	3028	3038	3048	3058	3068	3079	3089	360	
370	3099	3109	3119	3130	3140	3150	3160	3171	3181	3191	370	
380	3201	3212	3222	3232	3242	3253	3263	3273	3284	3294	380	
390	3304	3315	3325	3335	3346	3356	3366	3377	3387	3397	390	
400	3408	3418	3428	3439	3449	3460	3470	3480	3491	3501	400	
410	3512	3522	3533	3543	3553	3564	3574	3585	3595	3606	410	
420	3616	3627	3637	3648	3658	3669	3679	3690	3700	3711	420	
430	3721	3732	3742	3753	3764	3774	3785	3795	3806	3816	430	
440	3827	3838	3848	3859	3869	3880	3891	3901	3912	3922	440	
450	3933	3944	3954	3965	3976	3986	3997	4008	4018	4029	450	
460	4040	4050	4061	4072	4083	4093	4104	4115	4125	4136	460	
470	4147	4158	4168	4179	4190	4201	4211	4222	4233	4244	470	
480	4255	4265	4276	4287	4298	4309	4319	4330	4341	4352	480	
490	4363	4373	4384	4395	4406	4417	4428	4439	4449	4460	490	
500	4471	4482	4493	4504	4515	4526	4537	4548	4558	4569	500	
510	4580	4591	4602	4613	4624	4635	4646	4657	4668	4679	510	
520	4690	4701	4712	4723	4734	4745	4756	4767	4778	4789	520	
530	4800	4811	4822	4833	4844	4855	4866	4877	4888	4899	530	
540	4910	4922	4933	4944	4955	4966	4977	4988	4999	5010	540	
550	5021	5033	5044	5055	5066	5077	5088	5099	5111	5122	550	
560	5133	5144	5155	5166	5178	5189	5200	5211	5222	5234	560	
570	5245	5256	5267	5279	5290	5301	5312	5323	5335	5346	570	
580	5357	5369	5380	5391	5402	5414	5425	5436	5448	5459	580	
590	5470	5481	5493	5504	5515	5527	5538	5549	5561	5572	590	

Type R Thermocouple Table

Platinum – 13% Rhodium/Platinum, Electromotive force as a function of temperature

t90/°C	E/μV									t90/°C	
	0	1	2	3	4	5	6	7	8		9
600	5583	5595	5606	5618	5629	5640	5652	5663	5674	5686	600
610	5697	5709	5720	5731	5743	5754	5766	5777	5789	5800	610
620	5812	5823	5834	5846	5857	5869	5880	5892	5903	5915	620
630	5926	5938	5949	5961	5972	5984	5995	6007	6018	6030	630
640	6041	6053	6065	6076	6088	6099	6111	6122	6134	6146	640
650	6157	6169	6180	6192	6204	6215	6227	6238	6250	6262	650
660	6273	6285	6297	6308	6320	6332	6343	6355	6367	6378	660
670	6390	6402	6413	6425	6437	6448	6460	6472	6484	6495	670
680	6507	6519	6531	6542	6554	6566	6578	6589	6601	6613	680
690	6625	6636	6648	6660	6672	6684	6695	6707	6719	6731	690
700	6743	6755	6766	6778	6790	6802	6814	6826	6838	6849	700
710	6861	6873	6885	6897	6909	6921	6933	6945	6956	6968	710
720	6980	6992	7004	7016	7028	7040	7052	7064	7076	7088	720
730	7100	7112	7124	7136	7148	7160	7172	7184	7196	7208	730
740	7220	7232	7244	7256	7268	7280	7292	7304	7316	7328	740
750	7340	7352	7364	7376	7389	7401	7413	7425	7437	7449	750
760	7461	7473	7485	7498	7510	7522	7534	7546	7558	7570	760
770	7583	7595	7607	7619	7631	7644	7656	7668	7680	7692	770
780	7705	7717	7729	7741	7753	7766	7778	7790	7802	7815	780
790	7827	7839	7851	7864	7876	7888	7901	7913	7925	7938	790
800	7950	7962	7974	7987	7999	8011	8024	8036	8048	8061	800
810	8073	8086	8098	8110	8123	8135	8147	8160	8172	8185	810
820	8197	8209	8222	8234	8247	8259	8272	8284	8296	8309	820
830	8321	8334	8346	8359	8371	8384	8396	8409	8421	8434	830
840	8446	8459	8471	8484	8496	8509	8521	8534	8546	8559	840
850	8571	8584	8597	8609	8622	8634	8647	8659	8672	8685	850
860	8697	8710	8722	8735	8748	8760	8773	8785	8798	8811	860
870	8823	8836	8849	8861	8874	8887	8899	8912	8925	8937	870
880	8950	8963	8975	8988	9001	9014	9026	9039	9052	9065	880
890	9077	9090	9103	9115	9128	9141	9154	9167	9179	9192	890
900	9205	9218	9230	9243	9256	9269	9282	9294	9307	9320	900
910	9333	9346	9359	9371	9384	9397	9410	9423	9436	9449	910
920	9461	9474	9487	9500	9513	9526	9539	9552	9565	9578	920
930	9590	9603	9616	9629	9642	9655	9668	9681	9694	9707	930
940	9720	9733	9746	9759	9772	9785	9798	9811	9824	9837	940
950	9850	9863	9876	9889	9902	9915	9928	9941	9954	9967	950
960	9980	9993	10006	10019	10032	10046	10059	10072	10085	10098	960
970	10111	10124	10137	10150	10163	10177	10190	10203	10216	10229	970
980	10242	10255	10268	10282	10295	10308	10321	10334	10347	10361	980
990	10374	10387	10400	10413	10427	10440	10453	10466	10479	10493	990
1000	10506	10519	10532	10546	10559	10572	10585	10599	10612	10625	1000
1010	10638	10652	10665	10678	10692	10705	10718	10731	10745	10758	1010
1020	10771	10785	10798	10811	10825	10838	10851	10865	10878	10891	1020
1030	10905	10918	10932	10945	10958	10972	10985	10998	11012	11025	1030
1040	11039	11052	11065	11079	11092	11106	11119	11132	11146	11159	1040
1050	11173	11186	11200	11213	11227	11240	11253	11267	11280	11294	1050
1060	11307	11321	11334	11348	11361	11375	11388	11402	11415	11429	1060
1070	11442	11456	11469	11483	11496	11510	11524	11537	11551	11564	1070
1080	11578	11591	11605	11618	11632	11646	11659	11673	11686	11700	1080
1090	11714	11727	11741	11754	11768	11782	11795	11809	11822	11836	1090
1100	11850	11863	11877	11891	11904	11918	11931	11945	11959	11972	1100
1110	11986	12000	12013	12027	12041	12054	12068	12082	12096	12109	1110
1120	12123	12137	12150	12164	12178	12191	12205	12219	12233	12246	1120
1130	12260	12274	12288	12301	12315	12329	12342	12356	12370	12384	1130
1140	12397	12411	12425	12439	12453	12466	12480	12494	12508	12521	1140
1150	12535	12549	12563	12577	12590	12604	12618	12632	12646	12659	1150
1160	12673	12687	12701	12715	12729	12742	12756	12770	12784	12798	1160
1170	12812	12825	12839	12853	12867	12881	12895	12909	12922	12936	1170
1180	12950	12964	12978	12992	13006	13019	13033	13047	13061	13075	1180
1190	13089	13103	13117	13131	13145	13158	13172	13186	13200	13214	1190

Type R Thermocouple Table

Platinum 13% Rhodium/Platinum, Electromotive force as a function of temperature

		E/ μ V									
190/°C	0	1	2	3	4	5	6	7	8	9	190/°C
1200	13228	13242	13256	13270	13284	13298	13311	13325	13339	13353	1200
1210	13367	13381	13395	13409	13423	13437	13451	13465	13479	13493	1210
1220	13507	13521	13535	13549	13563	13577	13590	13604	13618	13632	1220
1230	13646	13660	13674	13688	13702	13716	13730	13744	13758	13772	1230
1240	13786	13800	13814	13828	13842	13856	13870	13884	13898	13912	1240
1250	13926	13940	13954	13968	13982	13996	14010	14024	14038	14052	1250
1260	14066	14081	14095	14109	14123	14137	14151	14165	14179	14193	1260
1270	14207	14221	14235	14249	14263	14277	14291	14305	14319	14333	1270
1280	14347	14361	14375	14390	14404	14418	14432	14446	14460	14474	1280
1290	14488	14502	14516	14530	14544	14558	14572	14586	14601	14615	1290
1300	14629	14643	14657	14671	14685	14699	14713	14727	14741	14755	1300
1310	14770	14784	14798	14812	14826	14840	14854	14868	14882	14896	1310
1320	14911	14925	14939	14953	14967	14981	14995	15009	15023	15037	1320
1330	15052	15066	15080	15094	15108	15122	15136	15150	15164	15179	1330
1340	15193	15207	15221	15235	15249	15263	15277	15291	15306	15320	1340
1350	15334	15348	15362	15376	15390	15404	15419	15433	15447	15461	1350
1360	15475	15489	15503	15517	15531	15546	15560	15574	15588	15602	1360
1370	15616	15630	15645	15659	15673	15687	15701	15715	15729	15743	1370
1380	15758	15772	15786	15800	15814	15828	15842	15856	15871	15885	1380
1390	15899	15913	15927	15941	15955	15969	15984	15998	16012	16026	1390
1400	16040	16054	16068	16082	16097	16111	16125	16139	16153	16167	1400
1410	16181	16196	16210	16224	16238	16252	16266	16280	16294	16309	1410
1420	16323	16337	16351	16365	16379	16393	16407	16422	16436	16450	1420
1430	16464	16478	16492	16506	16520	16534	16549	16563	16577	16591	1430
1440	16605	16619	16633	16647	16662	16676	16690	16704	16718	16732	1440
1450	16746	16760	16774	16788	16803	16817	16831	16845	16859	16873	1450
1460	16887	16901	16915	16930	16944	16958	16972	16986	17000	17014	1460
1470	17028	17042	17056	17071	17085	17099	17113	17127	17141	17155	1470
1480	17169	17183	17197	17211	17225	17240	17254	17268	17282	17296	1480
1490	17310	17324	17338	17352	17366	17380	17394	17408	17423	17437	1490
1500	17451	17465	17479	17493	17507	17521	17535	17549	17563	17577	1500
1510	17591	17605	17619	17633	17647	17661	17676	17690	17704	17718	1510
1520	17732	17746	17760	17774	17788	17802	17816	17830	17844	17858	1520
1530	17872	17886	17900	17914	17928	17942	17956	17970	17984	17998	1530
1540	18012	18026	18040	18054	18068	18082	18096	18110	18124	18138	1540
1550	18152	18166	18180	18194	18208	18222	18236	18250	18264	18278	1550
1560	18292	18306	18320	18334	18348	18362	18376	18390	18404	18417	1560
1570	18431	18445	18459	18473	18487	18501	18515	18529	18543	18557	1570
1580	18571	18585	18599	18613	18627	18640	18654	18668	18682	18696	1580
1590	18710	18724	18738	18752	18766	18779	18793	18807	18821	18835	1590
1600	18849	18863	18877	18891	18904	18918	18932	18946	18960	18974	1600
1610	18988	19002	19015	19029	19043	19057	19071	19085	19098	19112	1610
1620	19126	19140	19154	19168	19181	19195	19209	19223	19237	19250	1620
1630	19264	19278	19292	19306	19319	19333	19347	19361	19375	19388	1630
1640	19402	19416	19430	19444	19457	19471	19485	19499	19512	19526	1640
1650	19540	19554	19567	19581	19595	19609	19622	19636	19650	19663	1650
1660	19677	19691	19705	19718	19732	19746	19759	19773	19787	19800	1660
1670	19814	19828	19841	19855	19869	19882	19896	19910	19923	19937	1670
1680	19951	19964	19978	19992	20005	20019	20032	20046	20060	20073	1680
1690	20087	20100	20114	20127	20141	20154	20168	20181	20195	20208	1690
1700	20222	20235	20249	20262	20275	20289	20302	20316	20329	20342	1700
1710	20356	20369	20382	20396	20409	20422	20436	20449	20462	20475	1710
1720	20488	20502	20515	20528	20541	20554	20567	20581	20594	20607	1720
1730	20620	20633	20646	20659	20672	20685	20698	20711	20724	20736	1730
1740	20749	20762	20775	20788	20801	20813	20826	20839	20852	20864	1740
1750	20877	20890	20902	20915	20928	20940	20953	20965	20978	20990	1750
1760	21003	21015	21027	21040	21052	21065	21077	21089	21101		1760

Type B Thermocouple Table

Platinum – 30% Rhodium/Platinum 6% Rhodium, Electromotive force as a function of temperature

		$E/\mu V$										
$t/90^{\circ}C$	0	1	2	3	4	5	6	7	8	9	$t/90^{\circ}C$	
0	0	0	0	-1	-1	-1	-1	-1	-2	-2	0	
10	-2	-2	-2	-2	-2	-2	-2	-2	-3	-3	10	
20	-3	-3	-3	-3	-3	-2	-2	-2	-2	-2	20	
30	-2	-2	-2	-2	-2	-1	-1	-1	-1	-1	30	
40	0	0	0	0	0	1	1	1	2	2	40	
50	2	3	3	3	4	4	4	5	5	6	50	
60	6	7	7	8	8	9	9	10	10	11	60	
70	11	12	12	13	14	14	15	15	16	17	70	
80	17	18	19	20	20	21	22	22	23	24	80	
90	25	26	26	27	28	29	30	31	31	32	90	
100	33	34	35	36	37	38	39	40	41	42	100	
110	43	44	45	46	47	48	49	50	51	52	110	
120	53	55	56	57	58	59	60	62	63	64	120	
130	65	66	68	69	70	72	73	74	75	77	130	
140	78	79	81	82	84	85	86	88	89	91	140	
150	92	94	95	96	98	99	101	102	104	106	150	
160	107	109	110	112	113	115	117	118	120	122	160	
170	123	125	127	128	130	132	134	135	137	139	170	
180	141	142	144	146	148	150	151	153	155	157	180	
190	159	161	163	165	166	168	170	172	174	176	190	
200	178	180	182	184	186	188	190	192	195	197	200	
210	199	201	203	205	207	209	212	214	216	218	210	
220	220	222	225	227	229	231	234	236	238	241	220	
230	243	245	248	250	252	255	257	259	262	264	230	
240	267	269	271	274	276	279	281	284	286	289	240	
250	291	294	296	299	301	304	307	309	312	314	250	
260	317	320	322	325	328	330	333	336	338	341	260	
270	344	347	349	352	355	358	360	363	366	369	270	
280	372	375	377	380	383	386	389	392	395	398	280	
290	401	404	407	410	413	416	419	422	425	428	290	
300	431	434	437	440	443	446	449	452	455	458	300	
310	462	465	468	471	474	478	481	484	487	490	310	
320	494	497	500	503	507	510	513	517	520	523	320	
330	527	530	533	537	540	544	547	550	554	557	330	
340	561	564	568	571	575	578	582	585	589	592	340	
350	596	599	603	607	610	614	617	621	625	628	350	
360	632	636	639	643	647	650	654	658	662	665	360	
370	669	673	677	680	684	688	692	696	700	703	370	
380	707	711	715	719	723	727	731	735	738	742	380	
390	746	750	754	758	762	766	770	774	778	782	390	
400	787	791	795	799	803	807	811	815	819	824	400	
410	828	832	836	840	844	849	853	857	861	866	410	
420	870	874	878	883	887	891	896	900	904	909	420	
430	913	917	922	926	930	935	939	944	948	953	430	
440	957	961	966	970	975	979	984	988	993	997	440	
450	1002	1007	1011	1016	1020	1025	1030	1034	1039	1043	450	
460	1048	1053	1057	1062	1067	1071	1076	1081	1086	1090	460	
470	1095	1100	1105	1109	1114	1119	1124	1129	1133	1138	470	
480	1143	1148	1153	1158	1163	1167	1172	1177	1182	1187	480	
490	1192	1197	1202	1207	1212	1217	1222	1227	1232	1237	490	
500	1242	1247	1252	1257	1262	1267	1272	1277	1282	1288	500	
510	1293	1298	1303	1308	1313	1318	1324	1329	1334	1339	510	
520	1344	1350	1355	1360	1365	1371	1376	1381	1387	1392	520	
530	1397	1402	1408	1413	1418	1424	1429	1435	1440	1445	530	
540	1451	1456	1462	1467	1472	1478	1483	1489	1494	1500	540	
550	1505	1511	1516	1522	1527	1533	1539	1544	1550	1555	550	
560	1561	1566	1572	1578	1583	1589	1595	1600	1606	1612	560	
570	1617	1623	1629	1634	1640	1646	1652	1657	1663	1669	570	
580	1675	1680	1686	1692	1698	1704	1709	1715	1721	1727	580	
590	1733	1739	1745	1750	1756	1762	1768	1774	1780	1786	590	
600	1792	1798	1804	1810	1816	1822	1828	1834	1840	1846	600	

Type B Thermocouple Table

Platinum – 30% Rhodium/Platinum 6% Rhodium, Electromotive force as a function of temperature

		E/ μ V									
190/°C	0	1	2	3	4	5	6	7	8	9	190/°C
610	1852	1858	1864	1870	1876	1882	1888	1894	1901	1907	610
620	1913	1919	1925	1931	1937	1944	1950	1956	1962	1968	620
630	1975	1981	1987	1993	1999	2006	2012	2018	2025	2031	630
640	2037	2043	2050	2056	2062	2069	2075	2082	2088	2094	640
650	2101	2107	2113	2120	2126	2133	2139	2146	2152	2158	650
660	2165	2171	2178	2184	2191	2197	2204	2210	2217	2224	660
670	2230	2237	2243	2250	2256	2263	2270	2276	2283	2289	670
680	2296	2303	2309	2316	2323	2329	2336	2343	2350	2356	680
690	2363	2370	2376	2383	2390	2397	2403	2410	2417	2424	690
700	2431	2437	2444	2451	2458	2465	2472	2479	2485	2492	700
710	2499	2506	2513	2520	2527	2534	2541	2548	2555	2562	710
720	2569	2576	2583	2590	2597	2604	2611	2618	2625	2632	720
730	2639	2646	2653	2660	2667	2674	2681	2688	2696	2703	730
740	2710	2717	2724	2731	2738	2746	2753	2760	2767	2775	740
750	2782	2789	2796	2803	2811	2818	2825	2833	2840	2847	750
760	2854	2862	2869	2876	2884	2891	2898	2906	2913	2921	760
770	2928	2935	2943	2950	2958	2965	2973	2980	2987	2995	770
780	3002	3010	3017	3025	3032	3040	3047	3055	3062	3070	780
790	3078	3085	3093	3100	3108	3116	3123	3131	3138	3146	790
800	3154	3161	3169	3177	3184	3192	3200	3207	3215	3223	800
810	3230	3238	3246	3254	3261	3269	3277	3285	3292	3300	810
820	3308	3316	3324	3331	3339	3347	3355	3363	3371	3379	820
830	3386	3394	3402	3410	3418	3426	3434	3442	3450	3458	830
840	3466	3474	3482	3490	3498	3506	3514	3522	3530	3538	840
850	3546	3554	3562	3570	3578	3586	3594	3602	3610	3618	850
860	3626	3634	3643	3651	3659	3667	3675	3683	3692	3700	860
870	3708	3716	3724	3732	3741	3749	3757	3765	3774	3782	870
880	3790	3798	3807	3815	3823	3832	3840	3848	3857	3865	880
890	3873	3882	3890	3898	3907	3915	3923	3932	3940	3949	890
900	3957	3965	3974	3982	3991	3999	4008	4016	4024	4033	900
910	4041	4050	4058	4067	4075	4084	4093	4101	4110	4118	910
920	4127	4135	4144	4152	4161	4170	4178	4187	4195	4204	920
930	4213	4221	4230	4239	4247	4256	4265	4273	4282	4291	930
940	4299	4308	4317	4326	4334	4343	4352	4360	4369	4378	940
950	4387	4396	4404	4413	4422	4431	4440	4448	4457	4466	950
960	4475	4484	4493	4501	4510	4519	4528	4537	4546	4555	960
970	4564	4573	4582	4591	4599	4608	4617	4626	4635	4644	970
980	4653	4662	4671	4680	4689	4698	4707	4716	4725	4734	980
990	4743	4753	4762	4771	4780	4789	4798	4807	4816	4825	990
1000	4834	4843	4853	4862	4871	4880	4889	4898	4908	4917	1000
1010	4926	4935	4944	4954	4963	4972	4981	4990	5000	5009	1010
1020	5018	5027	5037	5046	5055	5065	5074	5083	5092	5102	1020
1030	5111	5120	5130	5139	5148	5158	5167	5176	5186	5195	1030
1040	5205	5214	5223	5233	5242	5252	5261	5270	5280	5289	1040
1050	5299	5308	5318	5327	5337	5346	5356	5365	5375	5384	1050
1060	5394	5403	5413	5422	5432	5441	5451	5460	5470	5480	1060
1070	5489	5499	5508	5518	5528	5537	5547	5556	5566	5576	1070
1080	5585	5595	5605	5614	5624	5634	5643	5653	5663	5672	1080
1090	5682	5692	5702	5711	5721	5731	5740	5750	5760	5770	1090
1100	5780	5789	5799	5809	5819	5828	5838	5848	5858	5868	1100
1110	5878	5887	5897	5907	5917	5927	5937	5947	5956	5966	1110
1120	5976	5986	5996	6006	6016	6026	6036	6046	6055	6065	1120
1130	6075	6085	6095	6105	6115	6125	6135	6145	6155	6165	1130
1140	6175	6185	6195	6205	6215	6225	6235	6245	6256	6266	1140
1150	6276	6286	6296	6306	6316	6326	6336	6346	6356	6367	1150
1160	6377	6387	6397	6407	6417	6427	6438	6448	6458	6468	1160
1170	6478	6488	6499	6509	6519	6529	6539	6550	6560	6570	1170
1180	6580	6591	6601	6611	6621	6632	6642	6652	6663	6673	1180
1190	6683	6693	6704	6714	6724	6735	6745	6755	6766	6776	1190
1200	6786	6797	6807	6818	6828	6838	6849	6859	6869	6880	1200
1210	6890	6901	6911	6922	6932	6942	6953	6963	6974	6984	1210

Type B Thermocouple Table

Platinum – 30% Rhodium/Platinum 6% Rhodium, Electromotive force as a function of temperature

		E/ μ V									
t/°C	0	1	2	3	4	5	6	7	8	9	t/°C
1220	6995	7005	7016	7026	7037	7047	7058	7068	7079	7089	1220
1230	7100	7110	7121	7131	7142	7152	7163	7173	7184	7194	1230
1240	7205	7216	7226	7237	7247	7258	7269	7279	7290	7300	1240
1250	7311	7322	7332	7343	7353	7364	7375	7385	7396	7407	1250
1260	7417	7428	7439	7449	7460	7471	7482	7492	7503	7514	1260
1270	7524	7535	7546	7557	7567	7578	7589	7600	7610	7621	1270
1280	7632	7643	7653	7664	7675	7686	7697	7707	7718	7729	1280
1290	7740	7751	7761	7772	7783	7794	7805	7816	7827	7837	1290
1300	7848	7859	7870	7881	7892	7903	7914	7924	7935	7946	1300
1310	7957	7968	7979	7990	8001	8012	8023	8034	8045	8056	1310
1320	8066	8077	8088	8099	8110	8121	8132	8143	8154	8165	1320
1330	8176	8187	8198	8209	8220	8231	8242	8253	8264	8275	1330
1340	8286	8298	8309	8320	8331	8342	8353	8364	8375	8386	1340
1350	8397	8408	8419	8430	8441	8453	8464	8475	8486	8497	1350
1360	8508	8519	8530	8542	8553	8564	8575	8586	8597	8608	1360
1370	8620	8631	8642	8653	8664	8675	8687	8698	8709	8720	1370
1380	8731	8743	8754	8765	8776	8787	8799	8810	8821	8832	1380
1390	8844	8855	8866	8877	8889	8900	8911	8922	8934	8945	1390
1400	8956	8967	8979	8990	9001	9013	9024	9035	9047	9058	1400
1410	9069	9080	9092	9103	9114	9126	9137	9148	9160	9171	1410
1420	9182	9194	9205	9216	9228	9239	9251	9262	9273	9285	1420
1430	9296	9307	9319	9330	9342	9353	9364	9376	9387	9398	1430
1440	9410	9421	9433	9444	9456	9467	9478	9490	9501	9513	1440
1450	9524	9536	9547	9558	9570	9581	9593	9604	9616	9627	1450
1460	9639	9650	9662	9673	9684	9696	9707	9719	9730	9742	1460
1470	9753	9765	9776	9788	9799	9811	9822	9834	9845	9857	1470
1480	9868	9880	9891	9903	9914	9926	9937	9949	9961	9972	1480
1490	9984	9995	10007	10018	10030	10041	10053	10064	10076	10088	1490
1500	10099	10111	10122	10134	10145	10157	10168	10180	10192	10203	1500
1510	10215	10226	10238	10249	10261	10273	10284	10296	10307	10319	1510
1520	10331	10342	10354	10365	10377	10389	10400	10412	10423	10435	1520
1530	10447	10458	10470	10482	10493	10505	10516	10528	10540	10551	1530
1540	10563	10575	10586	10598	10609	10621	10633	10644	10656	10668	1540
1550	10679	10691	10703	10714	10726	10738	10749	10761	10773	10784	1550
1560	10796	10808	10819	10831	10843	10854	10866	10877	10889	10901	1560
1570	10913	10924	10936	10948	10959	10971	10983	10994	11006	11018	1570
1580	11029	11041	11053	11064	11076	11088	11099	11111	11123	11134	1580
1590	11146	11158	11169	11181	11193	11205	11216	11228	11240	11251	1590
1600	11263	11275	11286	11298	11310	11321	11333	11345	11357	11368	1600
1610	11380	11392	11403	11415	11427	11438	11450	11462	11474	11485	1610
1620	11497	11509	11520	11532	11544	11555	11567	11579	11591	11602	1620
1630	11614	11626	11637	11649	11661	11673	11684	11696	11708	11719	1630
1640	11731	11743	11754	11766	11778	11790	11801	11813	11825	11836	1640
1650	11848	11860	11871	11883	11895	11907	11918	11930	11942	11953	1650
1660	11965	11977	11988	12000	12012	12024	12035	12047	12059	12070	1660
1670	12082	12094	12105	12117	12129	12141	12152	12164	12176	12187	1670
1680	12199	12211	12222	12234	12246	12257	12269	12281	12292	12304	1680
1690	12316	12327	12339	12351	12363	12374	12386	12398	12409	12421	1690
1700	12433	12444	12456	12468	12479	12491	12503	12514	12526	12538	1700
1710	12549	12561	12572	12584	12596	12607	12619	12631	12642	12654	1710
1720	12666	12677	12689	12701	12712	12724	12736	12747	12759	12770	1720
1730	12782	12794	12805	12817	12829	12840	12852	12863	12875	12887	1730
1740	12898	12910	12921	12933	12945	12956	12968	12980	12991	13003	1740
1750	13014	13026	13037	13049	13061	13072	13084	13095	13107	13119	1750
1760	13130	13142	13153	13165	13176	13188	13200	13211	13223	13234	1760
1770	13246	13257	13269	13280	13292	13304	13315	13327	13338	13350	1770
1780	13361	13373	13384	13396	13407	13419	13430	13442	13453	13465	1780
1790	13476	13488	13499	13511	13522	13534	13545	13557	13568	13580	1790
1800	13591	13603	13614	13626	13637	13649	13660	13672	13683	13694	1800
1810	13706	13717	13729	13740	13752	13763	13775	13786	13797	13809	1810
1820	13820										1820

Type N Thermocouple Table

Nickel-Chromium-Silicon/Nickel-Silicon, Electromotive force as a function of temperature

		E/ μ V									
t/90/°C	0	1	2	3	4	5	6	7	8	9	t/90/°C
0	0	26	52	78	104	130	156	182	208	235	0
10	261	287	313	340	366	393	419	446	472	499	10
20	525	552	578	605	632	659	685	712	739	766	20
30	793	820	847	874	901	928	955	983	1010	1037	30
40	1065	1092	1119	1147	1174	1202	1229	1257	1284	1312	40
50	1340	1368	1395	1423	1451	1479	1507	1535	1563	1591	50
60	1619	1647	1675	1703	1732	1760	1788	1817	1845	1873	60
70	1902	1930	1959	1988	2016	2045	2074	2102	2131	2160	70
80	2189	2218	2247	2276	2305	2334	2363	2392	2421	2450	80
90	2480	2509	2538	2568	2597	2626	2656	2685	2715	2744	90
100	2774	2804	2833	2863	2893	2923	2953	2983	3012	3042	100
110	3072	3102	3133	3163	3193	3223	3253	3283	3314	3344	110
120	3374	3405	3435	3466	3496	3527	3557	3588	3619	3649	120
130	3680	3711	3742	3772	3803	3834	3865	3896	3927	3958	130
140	3989	4020	4051	4083	4114	4145	4176	4208	4239	4270	140
150	4302	4333	4365	4396	4428	4459	4491	4523	4554	4586	150
160	4618	4650	4681	4713	4745	4777	4809	4841	4873	4905	160
170	4937	4969	5001	5033	5066	5098	5130	5162	5195	5227	170
180	5259	5292	5324	5357	5389	5422	5454	5487	5520	5552	180
190	5585	5618	5650	5683	5716	5749	5782	5815	5847	5880	190
200	5913	5946	5979	6013	6046	6079	6112	6145	6178	6211	200
210	6245	6278	6311	6345	6378	6411	6445	6478	6512	6545	210
220	6579	6612	6646	6680	6713	6747	6781	6814	6848	6882	220
230	6916	6949	6983	7017	7051	7085	7119	7153	7187	7221	230
240	7255	7289	7323	7357	7392	7426	7460	7494	7528	7563	240
250	7597	7631	7666	7700	7734	7769	7803	7838	7872	7907	250
260	7941	7976	8010	8045	8080	8114	8149	8184	8218	8253	260
270	8288	8323	8358	8392	8427	8462	8497	8532	8567	8602	270
280	8637	8672	8707	8742	8777	8812	8847	8882	8918	8953	280
290	8988	9023	9058	9094	9129	9164	9200	9235	9270	9306	290
300	9341	9377	9412	9448	9483	9519	9554	9590	9625	9661	300
310	9696	9732	9768	9803	9839	9875	9910	9946	9982	10018	310
320	10054	10089	10125	10161	10197	10233	10269	10305	10341	10377	320
330	10413	10449	10485	10521	10557	10593	10629	10665	10701	10737	330
340	10774	10810	10846	10882	10918	10955	10991	11027	11064	11100	340
350	11136	11173	11209	11245	11282	11318	11355	11391	11428	11464	350
360	11501	11537	11574	11610	11647	11683	11720	11757	11793	11830	360
370	11867	11903	11940	11977	12013	12050	12087	12124	12160	12197	370
380	12234	12271	12308	12345	12382	12418	12455	12492	12529	12566	380
390	12603	12640	12677	12714	12751	12788	12825	12862	12899	12937	390
400	12974	13011	13048	13085	13122	13159	13197	13234	13271	13308	400
410	13346	13383	13420	13457	13495	13532	13569	13607	13644	13682	410
420	13719	13756	13794	13831	13869	13906	13944	13981	14019	14056	420
430	14094	14131	14169	14206	14244	14281	14319	14356	14394	14432	430
440	14469	14507	14545	14582	14620	14658	14695	14733	14771	14809	440
450	14846	14884	14922	14960	14998	15035	15073	15111	15149	15187	450
460	15225	15262	15300	15338	15376	15414	15452	15490	15528	15566	460
470	15604	15642	15680	15718	15756	15794	15832	15870	15908	15946	470
480	15984	16022	16060	16099	16137	16175	16213	16251	16289	16327	480
490	16366	16404	16442	16480	16518	16557	16595	16633	16671	16710	490
500	16748	16786	16824	16863	16901	16939	16978	17016	17054	17093	500
510	17131	17169	17208	17246	17285	17323	17361	17400	17438	17477	510
520	17515	17554	17592	17630	17669	17707	17746	17784	17823	17861	520
530	17900	17938	17977	18016	18054	18093	18131	18170	18208	18247	530
540	18286	18324	18363	18401	18440	18479	18517	18556	18595	18633	540
550	18672	18711	18749	18788	18827	18865	18904	18943	18982	19020	550
560	19059	19098	19136	19175	19214	19253	19292	19330	19369	19408	560
570	19447	19485	19524	19563	19602	19641	19680	19718	19757	19796	570
580	19835	19874	19913	19952	19990	20029	20068	20107	20146	20185	580
590	20224	20263	20302	20341	20379	20418	20457	20496	20535	20574	590

9

Type N Thermocouple Table

Nickel-Chromium-Silicon/Nickel-Silicon, Electromotive force as a function of temperature

190/°C	E/ μ V									190/°C	
0	1	2	3	4	5	6	7	8	9	190/°C	
600	20613	20652	20691	20730	20769	20808	20847	20886	20925	20964	600
610	21003	21042	21081	21120	21159	21198	21237	21276	21315	21354	610
620	21393	21432	21471	21510	21549	21588	21628	21667	21706	21745	620
630	21784	21823	21862	21901	21940	21979	22018	22058	22097	22136	630
640	22175	22214	22253	22292	22331	22370	22410	22449	22488	22527	640
650	22566	22605	22645	22684	22723	22762	22801	22840	22879	22919	650
660	22958	22997	23036	23075	23115	23154	23193	23232	23271	23311	660
670	23350	23389	23428	23467	23507	23546	23585	23624	23663	23703	670
680	23742	23781	23820	23860	23899	23938	23977	24016	24056	24095	680
690	24134	24173	24213	24252	24291	24330	24370	24409	24448	24487	690
700	24527	24566	24605	24644	24684	24723	24762	24801	24841	24880	700
710	24919	24959	24998	25037	25076	25116	25155	25194	25233	25273	710
720	25312	25351	25391	25430	25469	25508	25548	25587	25626	25666	720
730	25705	25744	25783	25823	25862	25901	25941	25980	26019	26058	730
740	26098	26137	26176	26216	26255	26294	26333	26373	26412	26451	740
750	26491	26530	26569	26608	26648	26687	26726	26766	26805	26844	750
760	26883	26923	26962	27001	27041	27080	27119	27158	27198	27237	760
770	27276	27316	27355	27394	27433	27473	27512	27551	27591	27630	770
780	27669	27708	27748	27787	27826	27866	27905	27944	27983	28023	780
790	28062	28101	28140	28180	28219	28258	28298	28337	28376	28415	790
800	28455	28494	28533	28572	28612	28651	28690	28729	28769	28808	800
810	28847	28886	28926	28965	29004	29043	29083	29122	29161	29200	810
820	29240	29279	29318	29357	29396	29436	29475	29514	29553	29593	820
830	29632	29671	29710	29749	29789	29828	29867	29906	29945	29985	830
840	30024	30063	30102	30141	30181	30220	30259	30298	30337	30377	840
850	30416	30455	30494	30533	30572	30612	30651	30690	30729	30768	850
860	30807	30846	30886	30925	30964	31003	31042	31081	31120	31160	860
870	31199	31238	31277	31316	31355	31394	31433	31473	31512	31551	870
880	31590	31629	31668	31707	31746	31785	31824	31864	31903	31942	880
890	31981	32020	32059	32098	32137	32176	32215	32254	32293	32332	890
900	32371	32410	32449	32488	32527	32566	32606	32645	32684	32723	900
910	32762	32801	32840	32879	32918	32957	32996	33035	33074	33112	910
920	33151	33190	33229	33268	33307	33346	33385	33424	33463	33502	920
930	33541	33580	33619	33658	33697	33736	33775	33813	33852	33891	930
940	33930	33969	34008	34047	34086	34125	34163	34202	34241	34280	940
950	34319	34358	34397	34435	34474	34513	34552	34591	34630	34668	950
960	34707	34746	34785	34824	34862	34901	34940	34979	35017	35056	960
970	35095	35134	35173	35211	35250	35289	35327	35366	35405	35444	970
980	35482	35521	35560	35599	35637	35676	35715	35753	35792	35831	980
990	35869	35908	35947	35985	36024	36063	36101	36140	36178	36217	990
1000	36256	36294	36333	36371	36410	36449	36487	36526	36564	36603	1000
1010	36641	36680	36719	36757	36796	36834	36873	36911	36950	36988	1010
1020	37027	37066	37104	37142	37181	37219	37258	37296	37335	37373	1020
1030	37411	37450	37488	37527	37565	37604	37642	37680	37719	37757	1030
1040	37796	37834	37872	37911	37949	37987	38026	38064	38102	38141	1040
1050	38179	38217	38256	38294	38332	38371	38409	38447	38485	38524	1050
1060	38562	38600	38638	38677	38715	38753	38791	38830	38868	38906	1060
1070	38944	38982	39021	39059	39097	39135	39173	39211	39249	39288	1070
1080	39326	39364	39402	39440	39478	39516	39554	39592	39631	39669	1080
1090	39707	39745	39783	39821	39859	39897	39935	39973	40011	40049	1090
1100	40087	40125	40163	40201	40239	40277	40315	40352	40390	40428	1100
1110	40466	40504	40542	40580	40618	40656	40694	40731	40769	40807	1110
1120	40845	40883	40921	40958	40996	41034	41072	41110	41147	41185	1120
1130	41223	41261	41298	41336	41374	41412	41449	41487	41525	41562	1130
1140	41600	41638	41675	41713	41751	41788	41826	41864	41901	41939	1140
1150	41977	42014	42052	42089	42127	42165	42202	42240	42277	42315	1150
1160	42352	42390	42427	42465	42502	42540	42577	42615	42652	42690	1160
1170	42727	42765	42802	42839	42877	42914	42952	42989	43026	43064	1170
1180	43101	43138	43176	43213	43250	43288	43325	43362	43400	43437	1180
1190	43474	43511	43549	43586	43623	43660	43698	43735	43772	43809	1190

Type N Thermocouple Table

Nickel-Chromium-Silicon/Nickel-Silicon, Electromotive force as a function of temperature

		E/ μ V									
t ₉₀ /°C	0	1	2	3	4	5	6	7	8	9	t ₉₀ /°C
1200	43846	43884	43921	43958	43995	44032	44069	44106	44144	44181	1200
1210	44218	44255	44292	44329	44366	44403	44440	44477	44515	44551	1210
1220	44588	44625	44662	44699	44736	44773	44810	44847	44884	44921	1220
1230	44958	44995	45032	45069	45105	45142	45179	45216	45253	45290	1230
1240	45326	45363	45400	45437	45474	45510	45547	45584	45621	45657	1240
1250	45694	45731	45767	45804	45841	45877	45914	45951	45987	46024	1250
1260	46060	46097	46133	46170	46207	46243	46280	46316	46353	46389	1260
1270	46425	46462	46498	46535	46571	46608	46644	46680	46717	46753	1270
1280	46789	46826	46862	46898	46935	46971	47007	47043	47079	47116	1280
1290	47152	47188	47224	47260	47296	47333	47369	47405	47441	47477	1290
1300	47513										1300

t ₉₀ /°C	0	-1	-2	-3	-4	-5	-6	-7	-8	-9	t ₉₀ /°C
-270	-4345										-270
-260	-4336	-4337	-4339	-4340	-4341	-4342	-4343	-4344	-4344	-4345	-260
-250	-4313	-4316	-4319	-4321	-4324	-4326	-4328	-4330	-4332	-4334	-250
-240	-4277	-4281	-4285	-4289	-4293	-4297	-4300	-4304	-4307	-4310	-240
-230	-4226	-4232	-4238	-4243	-4248	-4254	-4258	-4263	-4268	-4273	-230
-220	-4162	-4169	-4176	-4183	-4189	-4196	-4202	-4209	-4215	-4221	-220
-210	-4083	-4091	-4100	-4108	-4116	-4124	-4132	-4140	-4147	-4154	-210
-200	-3990	-4000	-4010	-4020	-4029	-4038	-4048	-4057	-4066	-4074	-200
-190	-3884	-3896	-3907	-3918	-3928	-3939	-3950	-3960	-3970	-3980	-190
-180	-3766	-3778	-3790	-3803	-3815	-3827	-3838	-3850	-3862	-3873	-180
-170	-3634	-3648	-3662	-3675	-3688	-3702	-3715	-3728	-3740	-3753	-170
-160	-3491	-3506	-3521	-3535	-3550	-3564	-3578	-3593	-3607	-3621	-160
-150	-3336	-3352	-3368	-3384	-3400	-3415	-3431	-3446	-3461	-3476	-150
-140	-3171	-3188	-3205	-3221	-3238	-3255	-3271	-3288	-3304	-3320	-140
-130	-2994	-3012	-3030	-3048	-3066	-3084	-3101	-3119	-3136	-3153	-130
-120	-2808	-2827	-2846	-2865	-2883	-2902	-2921	-2939	-2958	-2976	-120
-110	-2612	-2632	-2652	-2672	-2691	-2711	-2730	-2750	-2769	-2789	-110
-100	-2407	-2428	-2448	-2469	-2490	-2510	-2531	-2551	-2571	-2592	-100
-90	-2193	-2215	-2237	-2258	-2280	-2301	-2322	-2344	-2365	-2386	-90
-80	-1972	-1995	-2017	-2039	-2062	-2084	-2106	-2128	-2150	-2172	-80
-70	-1744	-1767	-1790	-1813	-1836	-1859	-1882	-1905	-1927	-1950	-70
-60	-1509	-1533	-1557	-1580	-1604	-1627	-1651	-1674	-1698	-1721	-60
-50	-1269	-1293	-1317	-1341	-1366	-1390	-1414	-1438	-1462	-1485	-50
-40	-1023	-1048	-1072	-1097	-1122	-1146	-1171	-1195	-1220	-1244	-40
-30	-772	-798	-823	-848	-873	-898	-923	-948	-973	-998	-30
-20	-518	-544	-569	-595	-620	-646	-671	-696	-722	-747	-20
-10	-260	-286	-312	-338	-364	-390	-415	-441	-467	-492	-10
0	0	-26	-52	-78	-104	-131	-157	-183	-209	-234	0

Type K Thermocouple Table

Nickel-Chromium/Nickel-Aluminium, Electromotive force as a function of temperature

		$E/\mu V$									
t/°C	0	1	2	3	4	5	6	7	8	9	t/°C
0	0	39	79	119	158	198	238	277	317	357	0
10	397	437	477	517	557	597	637	677	718	758	10
20	798	838	879	919	960	1000	1041	1081	1122	1163	20
30	1203	1244	1285	1326	1366	1407	1448	1489	1530	1571	30
40	1612	1653	1694	1735	1776	1817	1858	1899	1941	1982	40
50	2023	2064	2106	2147	2188	2230	2271	2312	2354	2395	50
60	2436	2478	2519	2561	2602	2644	2685	2727	2768	2810	60
70	2851	2893	2934	2976	3017	3059	3100	3142	3184	3225	70
80	3267	3308	3350	3391	3433	3474	3516	3557	3599	3640	80
90	3682	3723	3765	3806	3848	3889	3931	3972	4013	4055	90
100	4096	4138	4179	4220	4262	4303	4344	4385	4427	4468	100
110	4509	4550	4591	4633	4674	4715	4756	4797	4838	4879	110
120	4920	4961	5002	5043	5084	5124	5165	5206	5247	5288	120
130	5328	5369	5410	5450	5491	5532	5572	5613	5653	5694	130
140	5735	5775	5815	5856	5896	5937	5977	6017	6058	6098	140
150	6138	6179	6219	6259	6299	6340	6380	6420	6460	6500	150
160	6540	6580	6620	6660	6701	6741	6781	6821	6861	6901	160
170	6941	6981	7021	7060	7100	7140	7180	7220	7260	7300	170
180	7340	7380	7420	7460	7500	7540	7579	7619	7659	7699	180
190	7739	7779	7819	7859	7899	7939	7979	8019	8059	8099	190
200	8138	8178	8218	8258	8298	8338	8378	8418	8458	8499	200
210	8539	8579	8619	8659	8699	8739	8779	8819	8860	8900	210
220	8940	8980	9020	9061	9101	9141	9181	9222	9262	9302	220
230	9343	9383	9423	9464	9504	9545	9585	9626	9666	9707	230
240	9747	9788	9828	9869	9909	9950	9991	10031	10072	10113	240
250	10153	10194	10235	10276	10316	10357	10398	10439	10480	10520	250
260	10561	10602	10643	10684	10725	10766	10807	10848	10889	10930	260
270	10971	11012	11053	11094	11135	11176	11217	11259	11300	11341	270
280	11382	11423	11465	11506	11547	11588	11630	11671	11712	11753	280
290	11795	11836	11877	11919	11960	12001	12043	12084	12126	12167	290
300	12209	12250	12291	12333	12374	12416	12457	12499	12540	12582	300
310	12624	12665	12707	12748	12790	12831	12873	12915	12956	12998	310
320	13040	13081	13123	13165	13206	13248	13290	13331	13373	13415	320
330	13457	13498	13540	13582	13624	13665	13707	13749	13791	13833	330
340	13874	13916	13958	14000	14042	14084	14126	14167	14209	14251	340
350	14293	14335	14377	14419	14461	14503	14545	14587	14629	14671	350
360	14713	14755	14797	14839	14881	14923	14965	15007	15049	15091	360
370	15133	15175	15217	15259	15301	15343	15385	15427	15469	15511	370
380	15554	15596	15638	15680	15722	15764	15806	15849	15891	15933	380
390	15975	16017	16059	16102	16144	16186	16228	16270	16313	16355	390
400	16397	16439	16482	16524	16566	16608	16651	16693	16735	16778	400
410	16820	16862	16904	16947	16989	17031	17074	17116	17158	17201	410
420	17243	17285	17328	17370	17413	17455	17497	17540	17582	17624	420
430	17667	17709	17752	17794	17837	17879	17921	17964	18006	18049	430
440	18091	18134	18176	18218	18261	18303	18346	18388	18431	18473	440
450	18516	18558	18601	18643	18686	18728	18771	18813	18856	18898	450
460	18941	18983	19026	19068	19111	19154	19196	19239	19281	19324	460
470	19366	19409	19451	19494	19537	19579	19622	19664	19707	19750	470
480	19792	19835	19877	19920	19962	20005	20048	20090	20133	20175	480
490	20218	20261	20303	20346	20389	20431	20474	20516	20559	20602	490
500	20644	20687	20730	20772	20815	20857	20900	20943	20985	21028	500
510	21071	21113	21156	21199	21241	21284	21326	21369	21412	21454	510
520	21497	21540	21582	21625	21668	21710	21753	21796	21838	21881	520
530	21924	21966	22009	22052	22094	22137	22179	22222	22265	22307	530
540	22350	22393	22435	22478	22521	22563	22606	22649	22691	22734	540
550	22776	22819	22862	22904	22947	22990	23032	23075	23117	23160	550
560	23203	23245	23288	23331	23373	23416	23458	23501	23544	23586	560
570	23629	23671	23714	23757	23799	23842	23884	23927	23970	24012	570
580	24055	24097	24140	24182	24225	24267	24310	24353	24395	24438	580
590	24480	24523	24565	24608	24650	24693	24735	24778	24820	24863	590

Type K Thermocouple Table

Nickel-Chromium/Nickel-Aluminium, Electromotive force as a function of temperature

190/°C	E/ μ V									190/°C	
0	1	2	3	4	5	6	7	8	9		
600	24905	24948	24990	25033	25075	25118	25160	25203	25245	25288	600
610	25330	25373	25415	25458	25500	25543	25585	25627	25670	25712	610
620	25755	25797	25840	25882	25924	25967	26009	26052	26094	26136	620
630	26179	26221	26263	26306	26348	26390	26433	26475	26517	26560	630
640	26602	26644	26687	26729	26771	26814	26856	26898	26940	26983	640
650	27025	27067	27109	27152	27194	27236	27278	27320	27363	27405	650
660	27447	27489	27531	27574	27616	27658	27700	27742	27784	27826	660
670	27869	27911	27953	27995	28037	28079	28121	28163	28205	28247	670
680	28289	28332	28374	28416	28458	28500	28542	28584	28626	28668	680
690	28710	28752	28794	28835	28877	28919	28961	29003	29045	29087	690
700	29129	29171	29213	29255	29297	29338	29380	29422	29464	29506	700
710	29548	29590	29631	29673	29715	29757	29798	29840	29882	29924	710
720	29965	30007	30049	30090	30132	30174	30216	30257	30299	30341	720
730	30382	30424	30466	30507	30549	30590	30632	30674	30715	30757	730
740	30798	30840	30881	30923	30964	31006	31047	31089	31130	31172	740
750	31213	31255	31296	31338	31379	31421	31462	31504	31545	31586	750
760	31628	31669	31710	31752	31793	31834	31876	31917	31958	32000	760
770	32041	32082	32124	32165	32206	32247	32289	32330	32371	32412	770
780	32453	32495	32536	32577	32618	32659	32700	32742	32783	32824	780
790	32865	32906	32947	32988	33029	33070	33111	33152	33193	33234	790
800	33275	33316	33357	33398	33439	33480	33521	33562	33603	33644	800
810	33685	33726	33767	33808	33848	33889	33930	33971	34012	34053	810
820	34093	34134	34175	34216	34257	34297	34338	34379	34420	34460	820
830	34501	34542	34582	34623	34664	34704	34745	34786	34826	34867	830
840	34908	34948	34989	35029	35070	35110	35151	35192	35232	35273	840
850	35313	35354	35394	35435	35475	35516	35556	35596	35637	35677	850
860	35718	35758	35798	35839	35879	35920	35960	36000	36041	36081	860
870	36121	36162	36202	36242	36282	36323	36363	36403	36443	36484	870
880	36524	36564	36604	36644	36685	36725	36765	36805	36845	36885	880
890	36925	36965	37006	37046	37086	37126	37166	37206	37246	37286	890
900	37326	37366	37406	37446	37486	37526	37566	37606	37646	37686	900
910	37725	37765	37805	37845	37885	37925	37965	38005	38044	38084	910
920	38124	38164	38204	38244	38283	38323	38363	38402	38442	38482	920
930	38522	38561	38601	38641	38680	38720	38760	38799	38839	38878	930
940	38918	38958	38997	39037	39076	39116	39155	39195	39235	39274	940
950	39314	39353	39393	39432	39471	39511	39550	39590	39629	39669	950
960	39708	39747	39787	39826	39866	39905	39944	39984	40023	40062	960
970	40101	40141	40180	40219	40259	40298	40337	40376	40415	40455	970
980	40494	40533	40572	40611	40651	40690	40729	40768	40807	40846	980
990	40885	40924	40963	41002	41042	41081	41120	41159	41198	41237	990
1000	41276	41315	41354	41393	41431	41470	41509	41548	41587	41626	1000
1010	41665	41704	41743	41781	41820	41859	41898	41937	41976	42014	1010
1020	42053	42092	42131	42169	42208	42247	42286	42324	42363	42402	1020
1030	42440	42479	42518	42556	42595	42633	42672	42711	42749	42788	1030
1040	42826	42865	42903	42942	42980	43019	43057	43096	43134	43173	1040
1050	43211	43250	43288	43327	43365	43403	43442	43480	43518	43557	1050
1060	43595	43633	43672	43710	43748	43787	43825	43863	43901	43940	1060
1070	43978	44016	44054	44092	44130	44169	44207	44245	44283	44321	1070
1080	44359	44397	44435	44473	44512	44550	44588	44626	44664	44702	1080
1090	44740	44778	44816	44853	44891	44929	44967	45005	45043	45081	1090
1100	45119	45157	45194	45232	45270	45308	45346	45383	45421	45459	1100
1110	45497	45534	45572	45610	45647	45685	45723	45760	45798	45836	1110
1120	45873	45911	45948	45986	46024	46061	46099	46136	46174	46211	1120
1130	46249	46286	46324	46361	46398	46436	46473	46511	46548	46585	1130
1140	46623	46660	46697	46735	46772	46809	46847	46884	46921	46958	1140
1150	46995	47033	47070	47107	47144	47181	47218	47256	47293	47330	1150
1160	47367	47404	47441	47478	47515	47552	47589	47626	47663	47700	1160
1170	47737	47774	47811	47848	47884	47921	47958	47995	48032	48069	1170
1180	48105	48142	48179	48216	48252	48289	48326	48363	48399	48436	1180
1190	48473	48509	48546	48582	48619	48656	48692	48729	48765	48802	1190

Type K Thermocouple Table

Nickel-Chromium/Nickel-Aluminium, Electromotive force as a function of temperature

		$E/\mu\text{V}$									
$t_{90}/^{\circ}\text{C}$	0	1	2	3	4	5	6	7	8	9	$t_{90}/^{\circ}\text{C}$
1200	48838	48875	48911	48948	48984	49021	49057	49093	49130	49166	1200
1210	49202	49239	49275	49311	49348	49384	49420	49456	49493	49529	1210
1220	49565	49601	49637	49674	49710	49746	49782	49818	49854	49890	1220
1230	49926	49962	49998	50034	50070	50106	50142	50178	50214	50250	1230
1240	50286	50322	50358	50393	50429	50465	50501	50537	50572	50608	1240
1250	50644	50680	50715	50751	50787	50822	50858	50894	50929	50965	1250
1260	51000	51036	51071	51107	51142	51178	51213	51249	51284	51320	1260
1270	51355	51391	51426	51461	51497	51532	51567	51603	51638	51673	1270
1280	51708	51744	51779	51814	51849	51885	51920	51955	51990	52025	1280
1290	52060	52095	52130	52165	52200	52235	52270	52305	52340	52375	1290
1300	52410	52445	52480	52515	52550	52585	52620	52654	52689	52724	1300
1310	52759	52794	52828	52863	52898	52932	52967	53002	53037	53071	1310
1320	53106	53140	53175	53210	53244	53279	53313	53348	53382	53417	1320
1330	53451	53486	53520	53555	53589	53623	53658	53692	53727	53761	1330
1340	53795	53830	53864	53898	53932	53967	54001	54035	54069	54104	1340
1350	54138	54172	54206	54240	54274	54308	54343	54377	54411	54445	1350
1360	54479	54513	54547	54581	54615	54649	54683	54717	54751	54785	1360
1370	54819	54852	54886								1370

Type K Thermocouple Table

Nickel-Chromium/Nickel-Aluminium, Electromotive force as a function of temperature

		$E/\mu\text{V}$									
$t_{90}/^{\circ}\text{C}$	0	-1	-2	-3	-4	-5	-6	-7	-8	-9	$t_{90}/^{\circ}\text{C}$
-270	-6458										-270
-260	-6441	-6444	-6446	-6448	-6450	-6452	-6453	-6455	-6456	-6457	-260
-250	-6404	-6408	-6413	-6417	-6421	-6425	-6429	-6432	-6435	-6438	-250
-240	-6344	-6351	-6358	-6364	-6370	-6377	-6382	-6388	-6393	-6399	-240
-230	-6262	-6271	-6280	-6289	-6297	-6306	-6314	-6322	-6329	-6337	-230
-220	-6158	-6170	-6181	-6192	-6202	-6213	-6223	-6233	-6243	-6252	-220
-210	-6035	-6048	-6061	-6074	-6087	-6099	-6111	-6123	-6135	-6147	-210
-200	-5891	-5907	-5922	-5936	-5951	-5965	-5980	-5994	-6007	-6021	-200
-190	-5730	-5747	-5763	-5780	-5797	-5813	-5829	-5845	-5861	-5876	-190
-180	-5550	-5569	-5588	-5606	-5624	-5642	-5660	-5678	-5695	-5713	-180
-170	-5354	-5374	-5395	-5415	-5435	-5454	-5474	-5493	-5512	-5531	-170
-160	-5141	-5163	-5185	-5207	-5228	-5250	-5271	-5292	-5313	-5333	-160
-150	-4913	-4936	-4960	-4983	-5006	-5029	-5052	-5074	-5097	-5119	-150
-140	-4669	-4694	-4719	-4744	-4768	-4793	-4817	-4841	-4865	-4889	-140
-130	-4411	-4437	-4463	-4490	-4516	-4542	-4567	-4593	-4618	-4644	-130
-120	-4138	-4166	-4194	-4221	-4249	-4276	-4303	-4330	-4357	-4384	-120
-110	-3852	-3882	-3911	-3939	-3968	-3997	-4025	-4054	-4082	-4110	-110
-100	-3554	-3584	-3614	-3645	-3675	-3705	-3734	-3764	-3794	-3823	-100
-90	-3243	-3274	-3306	-3337	-3368	-3400	-3431	-3462	-3492	-3523	-90
-80	-2920	-2953	-2986	-3018	-3050	-3083	-3115	-3147	-3179	-3211	-80
-70	-2587	-2620	-2654	-2688	-2721	-2755	-2788	-2821	-2854	-2887	-70
-60	-2243	-2278	-2312	-2347	-2382	-2416	-2450	-2485	-2519	-2553	-60
-50	-1889	-1925	-1961	-1996	-2032	-2067	-2103	-2138	-2173	-2208	-50
-40	-1527	-1564	-1600	-1637	-1673	-1709	-1745	-1782	-1818	-1854	-40
-30	-1156	-1194	-1231	-1268	-1305	-1343	-1380	-1417	-1453	-1490	-30
-20	-778	-816	-854	-892	-930	-968	-1006	-1043	-1081	-1119	-20
-10	-392	-431	-470	-508	-547	-586	-624	-663	-701	-739	-10
0	0	-39	-79	-118	-157	-197	-236	-275	-314	-353	0

Type E Thermocouple Table

Nickel-Chromium/Copper-Nickel, Electromotive force as a function of temperature

190/°C		E/ μ V									190/°C
		0	1	2	3	4	5	6	7	8	
0	0	59	118	176	235	294	354	413	472	532	0
10	591	651	711	770	830	890	950	1010	1071	1131	10
20	1192	1252	1313	1373	1434	1495	1556	1617	1678	1740	20
30	1801	1862	1924	1986	2047	2109	2171	2233	2295	2357	30
40	2420	2482	2545	2607	2670	2733	2795	2858	2921	2984	40
50	3048	3111	3174	3238	3301	3365	3429	3492	3556	3620	50
60	3685	3749	3813	3877	3942	4006	4071	4136	4200	4265	60
70	4330	4395	4460	4526	4591	4656	4722	4788	4853	4919	70
80	4985	5051	5117	5183	5249	5315	5382	5448	5514	5581	80
90	5648	5714	5781	5848	5915	5982	6049	6117	6184	6251	90
100	6319	6386	6454	6522	6590	6658	6725	6794	6862	6930	100
110	6998	7066	7135	7203	7272	7341	7409	7478	7547	7616	110
120	7685	7754	7823	7892	7962	8031	8101	8170	8240	8309	120
130	8379	8449	8519	8589	8659	8729	8799	8869	8940	9010	130
140	9081	9151	9222	9292	9363	9434	9505	9576	9647	9718	140
150	9789	9860	9931	10003	10074	10145	10217	10288	10360	10432	150
160	10503	10575	10647	10719	10791	10863	10935	11007	11080	11152	160
170	11224	11297	11369	11442	11514	11587	11660	11733	11805	11878	170
180	11951	12024	12097	12170	12243	12317	12390	12463	12537	12610	180
190	12684	12757	12831	12904	12978	13052	13126	13199	13273	13347	190
200	13421	13495	13569	13644	13718	13792	13866	13941	14015	14090	200
210	14164	14239	14313	14388	14463	14537	14612	14687	14762	14837	210
220	14912	14987	15062	15137	15212	15287	15362	15438	15513	15588	220
230	15664	15739	15815	15890	15966	16041	16117	16193	16269	16344	230
240	16420	16496	16572	16648	16724	16800	16876	16952	17028	17104	240
250	17181	17257	17333	17409	17486	17562	17639	17715	17792	17868	250
260	17945	18021	18098	18175	18252	18328	18405	18482	18559	18636	260
270	18713	18790	18867	18944	19021	19098	19175	19252	19330	19407	270
280	19484	19561	19639	19716	19794	19871	19948	20026	20103	20181	280
290	20259	20336	20414	20492	20569	20647	20725	20803	20880	20958	290
300	21036	21114	21192	21270	21348	21426	21504	21582	21660	21739	300
310	21817	21895	21973	22051	22130	22208	22286	22365	22443	22522	310
320	22600	22678	22757	22835	22914	22993	23071	23150	23228	23307	320
330	23386	23464	23543	23622	23701	23780	23858	23937	24016	24095	330
340	24174	24253	24332	24411	24490	24569	24648	24727	24806	24885	340
350	24964	25044	25123	25202	25281	25360	25440	25519	25598	25678	350
360	25757	25836	25916	25995	26075	26154	26233	26313	26392	26472	360
370	26552	26631	26711	26790	26870	26950	27029	27109	27189	27268	370
380	27348	27428	27507	27587	27667	27747	27827	27907	27986	28066	380
390	28146	28226	28306	28386	28466	28546	28626	28706	28786	28866	390
400	28946	29026	29106	29186	29266	29346	29427	29507	29587	29667	400
410	29747	29827	29908	29988	30068	30148	30229	30309	30389	30470	410
420	30550	30630	30711	30791	30871	30952	31032	31112	31193	31273	420
430	31354	31434	31515	31595	31676	31756	31837	31917	31998	32078	430
440	32159	32239	32320	32400	32481	32562	32642	32723	32803	32884	440
450	32965	33045	33126	33207	33287	33368	33449	33529	33610	33691	450
460	33772	33852	33933	34014	34095	34175	34256	34337	34418	34498	460
470	34579	34660	34741	34822	34902	34983	35064	35145	35226	35307	470
480	35387	35468	35549	35630	35711	35792	35873	35954	36034	36115	480
490	36196	36277	36358	36439	36520	36601	36682	36763	36843	36924	490
500	37005	37086	37167	37248	37329	37410	37491	37572	37653	37734	500
510	37815	37896	37977	38058	38139	38220	38300	38381	38462	38543	510
520	38624	38705	38786	38867	38948	39029	39110	39191	39272	39353	520
530	39434	39515	39596	39677	39758	39839	39920	40001	40082	40163	530
540	40243	40324	40405	40486	40567	40648	40729	40810	40891	40972	540
550	41053	41134	41215	41296	41377	41457	41538	41619	41700	41781	550
560	41862	41943	42024	42105	42185	42266	42347	42428	42509	42590	560
570	42671	42751	42832	42913	42994	43075	43156	43236	43317	43398	570
580	43479	43560	43640	43721	43802	43883	43963	44044	44125	44206	580
590	44286	44367	44448	44529	44609	44690	44771	44851	44932	45013	590

Type E Thermocouple Table

Nickel-Chromium/Copper-Nickel, Electromotiveforce as a function of temperature

		$E/\mu\text{V}$									
$t_{90}/^{\circ}\text{C}$	0	1	2	3	4	5	6	7	8	9	$t_{90}/^{\circ}\text{C}$
600	45093	45174	45255	45335	45416	45497	45577	45658	45738	45819	600
610	45900	45980	46061	46141	46222	46302	46383	46463	46544	46624	610
620	46705	46785	46866	46946	47027	47107	47188	47268	47349	47429	620
630	47509	47590	47670	47751	47831	47911	47992	48072	48152	48233	630
640	48313	48393	48474	48554	48634	48715	48795	48875	48955	49035	640
650	49116	49196	49276	49356	49436	49517	49597	49677	49757	49837	650
660	49917	49997	50077	50157	50238	50318	50398	50478	50558	50638	660
670	50718	50798	50878	50958	51038	51118	51197	51277	51357	51437	670
680	51517	51597	51677	51757	51837	51916	51996	52076	52156	52236	680
690	52315	52395	52475	52555	52634	52714	52794	52873	52953	53033	690
700	53112	53192	53272	53351	53431	53510	53590	53670	53749	53829	700
710	53908	53988	54067	54147	54226	54306	54385	54465	54544	54624	710
720	54703	54782	54862	54941	55021	55100	55179	55259	55338	55417	720
730	55497	55576	55655	55734	55814	55893	55972	56051	56131	56210	730
740	56289	56368	56447	56526	56606	56685	56764	56843	56922	57001	740
750	57080	57159	57238	57317	57396	57475	57554	57633	57712	57791	750
760	57870	57949	58028	58107	58186	58265	58343	58422	58501	58580	760
770	58659	58738	58816	58895	58974	59053	59131	59210	59289	59367	770
780	59446	59525	59604	59682	59761	59839	59918	59997	60075	60154	780
790	60232	60311	60390	60468	60547	60625	60704	60782	60860	60937	790
800	61017	61096	61174	61253	61331	61409	61488	61566	61644	61723	800
810	61801	61879	61958	62036	62114	62192	62271	62349	62427	62505	810
820	62583	62662	62740	62818	62896	62974	63052	63130	63208	63286	820
830	63364	63442	63520	63598	63676	63754	63832	63910	63988	64066	830
840	64144	64222	64300	64377	64455	64533	64611	64689	64766	64844	840
850	64922	65000	65077	65155	65233	65310	65388	65465	65543	65621	850
860	65698	65776	65853	65931	66008	66086	66163	66241	66318	66396	860
870	66473	66550	66628	66705	66782	66860	66937	67014	67092	67169	870
880	67246	67323	67400	67478	67555	67632	67709	67786	67863	67940	880
890	68017	68094	68171	68248	68325	68402	68479	68556	68633	68710	890
900	68787	68863	68940	69017	69094	69171	69247	69324	69401	69477	900
910	69554	69631	69707	69784	69860	69937	70013	70090	70166	70243	910
920	70319	70396	70472	70548	70625	70701	70777	70854	70930	71006	920
930	71082	71159	71235	71311	71387	71463	71539	71615	71692	71768	930
940	71844	71920	71996	72072	72147	72223	72299	72375	72451	72527	940
950	72603	72678	72754	72830	72906	72981	73057	73133	73208	73284	950
960	73360	73435	73511	73586	73662	73738	73813	73889	73964	74040	960
970	74115	74190	74266	74341	74417	74492	74567	74643	74718	74793	970
980	74869	74944	75019	75095	75170	75245	75320	75395	75471	75546	980
990	75621	75696	75771	75847	75922	75997	76072	76147	76223	76298	990
1000	76373										1000

Type E Thermocouple Table

Nickel-Chromium/Copper-Nickel, Electromotiveforce as a function of temperature

		E/ μ V									
t ₉₀ /°	0	-1	-2	-3	-4	-5	-6	-7	-8	-9	t ₉₀ /°C
-270	-9835										-270
-260	-9797	-9802	-9808	-9813	-9817	-9821	-9825	-9828	-9831	-9833	-260
-250	-9718	-9728	-9737	-9746	-9754	-9762	-9770	-9777	-9784	-9790	-250
-240	-9604	-9617	-9630	-9642	-9654	-9666	-9677	-9688	-9698	-9709	-240
-230	-9455	-9471	-9487	-9503	-9519	-9534	-9548	-9563	-9577	-9591	-230
-220	-9274	-9293	-9313	-9331	-9350	-9368	-9386	-9404	-9421	-9438	-220
-210	-9063	-9085	-9107	-9129	-9151	-9172	-9193	-9214	-9234	-9254	-210
-200	-8825	-8850	-8874	-8899	-8923	-8947	-8971	-8994	-9017	-9040	-200
-190	-8561	-8588	-8616	-8643	-8669	-8696	-8722	-8748	-8774	-8799	-190
-180	-8273	-8303	-8333	-8362	-8391	-8420	-8449	-8477	-8505	-8533	-180
-170	-7963	-7995	-8027	-8059	-8090	-8121	-8152	-8183	-8213	-8243	-170
-160	-7632	-7666	-7700	-7733	-7767	-7800	-7833	-7866	-7899	-7931	-160
-150	-7279	-7315	-7351	-7387	-7423	-7458	-7493	-7528	-7563	-7597	-150
-140	-6907	-6945	-6983	-7021	-7058	-7096	-7133	-7170	-7206	-7243	-140
-130	-6516	-6556	-6596	-6636	-6675	-6714	-6753	-6792	-6831	-6869	-130
-120	-6107	-6149	-6191	-6232	-6273	-6314	-6355	-6396	-6436	-6476	-120
-110	-5681	-5724	-5767	-5810	-5853	-5896	-5939	-5981	-6023	-6065	-110
-100	-5237	-5282	-5327	-5372	-5417	-5461	-5505	-5549	-5593	-5637	-100
-90	-4777	-4824	-4871	-4917	-4963	-5009	-5055	-5101	-5147	-5192	-90
-80	-4302	-4350	-4398	-4446	-4494	-4542	-4589	-4636	-4684	-4731	-80
-70	-3811	-3861	-3911	-3960	-4009	-4058	-4107	-4156	-4205	-4254	-70
-60	-3306	-3357	-3408	-3459	-3510	-3561	-3611	-3661	-3711	-3761	-60
-50	-2787	-2840	-2892	-2944	-2996	-3048	-3100	-3152	-3204	-3255	-50
-40	-2255	-2309	-2362	-2416	-2469	-2523	-2576	-2629	-2682	-2735	-40
-30	-1709	-1765	-1820	-1874	-1929	-1984	-2038	-2093	-2147	-2201	-30
-20	-1152	-1208	-1264	-1320	-1376	-1432	-1488	-1543	-1599	-1654	-20
-10	-582	-639	-697	-754	-811	-868	-925	-982	-1039	-1095	-10
0	0	-59	-117	-176	-234	-292	-350	-408	-466	-524	0

Type T Thermocouple Table

Copper/Copper-Nickel, Electromotive force as a function of temperature

t ₉₀ /°C	E/ μ V									t ₉₀ /°C	
0	0	1	2	3	4	5	6	7	8	9	100
0	0	39	78	117	156	195	234	273	312	352	0
10	391	431	470	510	549	589	629	669	709	749	10
20	790	830	870	911	951	992	1033	1074	1114	1155	20
30	1196	1238	1279	1320	1362	1403	1445	1486	1528	1570	30
40	1612	1654	1696	1738	1780	1823	1865	1908	1950	1993	40
50	2036	2079	2122	2165	2208	2251	2294	2338	2381	2425	50
60	2468	2512	2556	2600	2643	2687	2732	2776	2820	2864	60
70	2909	2953	2998	3043	3087	3132	3177	3222	3267	3312	70
80	3358	3403	3448	3494	3539	3585	3631	3677	3722	3768	80
90	3814	3860	3907	3953	3999	4046	4092	4138	4185	4232	90
100	4279	4325	4372	4419	4466	4513	4561	4608	4655	4702	100
110	4750	4798	4845	4893	4941	4988	5036	5084	5132	5180	110
120	5228	5277	5325	5373	5422	5470	5519	5567	5616	5665	120
130	5714	5763	5812	5861	5910	5959	6008	6057	6107	6156	130
140	6206	6255	6305	6355	6404	6454	6504	6554	6604	6654	140
150	6704	6754	6805	6855	6905	6956	7006	7057	7107	7158	150
160	7209	7260	7310	7361	7412	7463	7515	7566	7617	7668	160
170	7720	7771	7823	7874	7926	7977	8029	8081	8133	8185	170
180	8237	8289	8341	8393	8445	8497	8550	8602	8654	8707	180
190	8759	8812	8865	8917	8970	9023	9076	9129	9182	9235	190
200	9288	9341	9395	9448	9501	9555	9608	9662	9715	9769	200
210	9822	9876	9930	9984	10038	10092	10146	10200	10254	10308	210
220	10362	10417	10471	10525	10580	10634	10689	10743	10798	10853	220
230	10907	10962	11017	11072	11127	11182	11237	11292	11347	11403	230
240	11458	11513	11569	11624	11680	11735	11791	11846	11902	11958	240
250	12013	12069	12125	12181	12237	12293	12349	12405	12461	12518	250
260	12574	12630	12687	12743	12799	12856	12912	12969	13026	13082	260
270	13139	13196	13253	13310	13366	13423	13480	13537	13595	13652	270
280	13709	13766	13823	13881	13938	13995	14053	14110	14168	14226	280
290	14283	14341	14399	14456	14514	14572	14630	14688	14746	14804	290
300	14862	14920	14978	15036	15095	15153	15211	15270	15328	15386	300
310	15445	15503	15562	15621	15679	15738	15797	15856	15914	15973	310
320	16032	16091	16150	16209	16268	16327	16387	16446	16505	16564	320
330	16624	16683	16742	16802	16861	16921	16980	17040	17100	17159	330
340	17219	17279	17339	17399	17458	17518	17578	17638	17698	17759	340
350	17819	17879	17939	17999	18060	18120	18180	18241	18301	18362	350
360	18422	18483	18543	18604	18665	18725	18786	18847	18908	18969	360
370	19030	19091	19152	19213	19274	19335	19396	19457	19518	19579	370
380	19641	19702	19763	19825	19886	19947	20009	20070	20132	20193	380
390	20255	20317	20378	20440	20502	20563	20625	20687	20748	20810	390
400	20872										400

Type T Thermocouple Table

Copper/Copper-Nickel, Electromotive force as a function of temperature

		E/ μ V									
190/ $^{\circ}$ C	0	-1	-2	-3	-4	-5	-6	-7	-8	-9	190/ $^{\circ}$ C
-270	-6258										-270
-260	-6232	-6236	-6239	-6242	-6245	-6248	-6251	-6253	-6255	-6256	-260
-250	-6180	-6187	-6193	-6198	-6204	-6209	-6214	-6219	-6223	-6228	-250
-240	-6105	-6114	-6122	-6130	-6138	-6146	-6153	-6160	-6167	-6174	-240
-230	-6007	-6017	-6028	-6038	-6049	-6059	-6068	-6078	-6087	-6096	-230
-220	-5888	-5901	-5914	-5926	-5938	-5950	-5962	-5973	-5985	-5996	-220
-210	-5753	-5767	-5782	-5795	-5809	-5823	-5836	-5850	-5863	-5876	-210
-200	-5603	-5619	-5634	-5650	-5665	-5680	-5695	-5710	-5724	-5739	-200
-190	-5439	-5456	-5473	-5489	-5506	-5523	-5539	-5555	-5571	-5587	-190
-180	-5261	-5279	-5297	-5316	-5334	-5351	-5369	-5387	-5404	-5421	-180
-170	-5070	-5089	-5109	-5128	-5148	-5167	-5186	-5205	-5224	-5242	-170
-160	-4865	-4886	-4907	-4928	-4949	-4969	-4989	-5010	-5030	-5050	-160
-150	-4648	-4671	-4693	-4715	-4737	-4759	-4780	-4802	-4823	-4844	-150
-140	-4419	-4443	-4466	-4489	-4512	-4535	-4558	-4581	-4604	-4626	-140
-130	-4177	-4202	-4226	-4251	-4275	-4300	-4324	-4348	-4372	-4395	-130
-120	-3923	-3949	-3975	-4000	-4026	-4052	-4077	-4102	-4127	-4152	-120
-110	-3657	-3684	-3711	-3738	-3765	-3791	-3818	-3844	-3871	-3897	-110
-100	-3379	-3407	-3435	-3463	-3491	-3519	-3547	-3574	-3602	-3629	-100
-90	-3089	-3118	-3148	-3177	-3206	-3235	-3264	-3293	-3322	-3350	-90
-80	-2788	-2818	-2849	-2879	-2910	-2940	-2970	-3000	-3030	-3059	-80
-70	-2476	-2507	-2539	-2571	-2602	-2633	-2664	-2695	-2726	-2757	-70
-60	-2153	-2186	-2218	-2251	-2283	-2316	-2348	-2380	-2412	-2444	-60
-50	-1819	-1853	-1887	-1920	-1954	-1987	-2021	-2054	-2087	-2120	-50
-40	-1475	-1510	-1545	-1579	-1614	-1648	-1683	-1717	-1751	-1785	-40
-30	-1121	-1157	-1192	-1228	-1264	-1299	-1335	-1370	-1405	-1440	-30
-20	-757	-794	-830	-867	-904	-940	-976	-1013	-1049	-1085	-20
-10	-383	-421	-459	-496	-534	-571	-608	-646	-683	-720	-10
0	0	-39	-77	-116	-154	-193	-231	-269	-307	-345	0

Type J Thermocouple Table

Iron/Copper-Nickel, Electromotive force as a function of temperature

		$E/\mu V$									
t/°C	0	1	2	3	4	5	6	7	8	9	t/°C
0	0	50	101	151	202	253	303	354	405	456	0
10	507	558	609	660	711	762	814	865	916	968	10
20	1019	1071	1122	1174	1226	1277	1329	1381	1433	1485	20
30	1537	1589	1641	1693	1745	1797	1849	1902	1954	2006	30
40	2059	2111	2164	2216	2269	2322	2374	2427	2480	2532	40
50	2585	2638	2691	2744	2797	2850	2903	2956	3009	3062	50
60	3116	3169	3222	3275	3329	3382	3436	3489	3543	3596	60
70	3650	3703	3757	3810	3864	3918	3971	4025	4079	4133	70
80	4187	4240	4294	4348	4402	4456	4510	4564	4618	4672	80
90	4726	4781	4835	4889	4943	4997	5052	5106	5160	5215	90
100	5269	5323	5378	5432	5487	5541	5595	5650	5705	5759	100
110	5814	5868	5923	5977	6032	6087	6141	6196	6251	6306	110
120	6360	6415	6470	6525	6579	6634	6689	6744	6799	6854	120
130	6909	6964	7019	7074	7129	7184	7239	7294	7349	7404	130
140	7459	7514	7569	7624	7679	7734	7789	7844	7900	7955	140
150	8010	8065	8120	8175	8231	8286	8341	8396	8452	8507	150
160	8562	8618	8673	8728	8783	8839	8894	8949	9005	9060	160
170	9115	9171	9226	9282	9337	9392	9448	9503	9559	9614	170
180	9669	9725	9780	9836	9891	9947	10002	10057	10113	10168	180
190	10224	10279	10335	10390	10446	10501	10557	10612	10668	10723	190
200	10779	10834	10890	10945	11001	11056	11112	11167	11223	11278	200
210	11334	11389	11445	11501	11556	11612	11667	11723	11778	11834	210
220	11889	11945	12000	12056	12111	12167	12222	12278	12334	12389	220
230	12445	12500	12556	12611	12667	12722	12778	12833	12889	12944	230
240	13000	13056	13111	13167	13222	13278	13333	13389	13444	13500	240
250	13555	13611	13666	13722	13777	13833	13888	13944	13999	14055	250
260	14110	14166	14221	14277	14332	14388	14443	14499	14554	14609	260
270	14665	14720	14776	14831	14887	14942	14998	15053	15109	15164	270
280	15219	15275	15330	15386	15441	15496	15552	15607	15663	15718	280
290	15773	15829	15884	15940	15995	16050	16106	16161	16217	16272	290
300	16327	16383	16438	16493	16549	16604	16659	16715	16770	16825	300
310	16881	16936	16991	17046	17102	17157	17212	17268	17323	17378	310
320	17434	17489	17544	17599	17655	17710	17765	17820	17876	17931	320
330	17986	18041	18097	18152	18207	18262	18318	18373	18428	18483	330
340	18538	18594	18649	18704	18759	18814	18870	18925	18980	19035	340
350	19090	19146	19201	19256	19311	19366	19422	19477	19532	19587	350
360	19642	19697	19753	19808	19863	19918	19973	20028	20083	20139	360
370	20194	20249	20304	20359	20414	20469	20525	20580	20635	20690	370
380	20745	20800	20855	20911	20966	21021	21076	21131	21186	21241	380
390	21297	21352	21407	21462	21517	21572	21627	21683	21738	21793	390
400	21848	21903	21958	22014	22069	22124	22179	22234	22289	22345	400
410	22400	22455	22510	22565	22620	22675	22731	22786	22841	22896	410
420	22952	23007	23062	23117	23172	23228	23283	23338	23393	23449	420
430	23504	23559	23614	23670	23725	23780	23835	23891	23946	24001	430
440	24057	24112	24167	24223	24278	24333	24389	24444	24499	24555	440
450	24610	24665	24721	24776	24832	24887	24943	24998	25053	25109	450
460	25164	25220	25275	25331	25386	25442	25497	25553	25608	25664	460
470	25720	25775	25831	25886	25942	25998	26053	26109	26165	26220	470
480	26276	26332	26387	26443	26499	26555	26610	26666	26722	26778	480
490	26834	26889	26945	27001	27057	27113	27169	27225	27281	27337	490
500	27393	27449	27505	27561	27617	27673	27729	27785	27841	27897	500
510	27953	28010	28066	28122	28178	28234	28291	28347	28403	28460	510
520	28516	28572	28629	28685	28741	28798	28854	28911	28967	29024	520
530	29080	29137	29194	29250	29307	29363	29420	29477	29534	29590	530
540	29647	29704	29761	29818	29874	29931	29988	30045	30102	30159	540
550	30216	30273	30330	30387	30444	30502	30559	30616	30673	30730	550
560	30788	30845	30902	30960	31017	31074	31132	31189	31247	31304	560
570	31362	31419	31477	31535	31592	31650	31708	31766	31823	31881	570
580	31939	31997	32055	32113	32171	32229	32287	32345	32403	32461	580
590	32519	32577	32636	32694	32752	32810	32869	32927	32985	33044	590

Type J Thermocouple Table

Iron/Copper-Nickel, Electromotive force as a function of temperature

190°C	E/ μ V									190°C	
0	1	2	3	4	5	6	7	8	9		
600	33102	33161	33219	33278	33337	33395	33454	33513	33571	33630	600
610	33689	33748	33807	33866	33925	33984	34043	34102	34161	34220	610
620	34279	34338	34397	34457	34516	34575	34635	34694	34754	34813	620
630	34873	34932	34992	35051	35111	35171	35230	35290	35350	35410	630
640	35470	35530	35590	35650	35710	35770	35830	35890	35950	36010	640
650	36071	36131	36191	36252	36312	36373	36433	36494	36554	36615	650
660	36675	36736	36797	36858	36918	36979	37040	37101	37162	37223	660
670	37284	37345	37406	37467	37528	37590	37651	37712	37773	37835	670
680	37896	37958	38019	38081	38142	38204	38265	38327	38389	38450	680
690	38512	38574	38636	38698	38760	38822	38884	38946	39008	39070	690
700	39132	39194	39256	39318	39381	39443	39505	39568	39630	39693	700
710	39755	39818	39880	39943	40005	40068	40131	40193	40256	40319	710
720	40382	40445	40508	40570	40633	40696	40759	40822	40886	40949	720
730	41012	41075	41138	41201	41265	41328	41391	41455	41518	41581	730
740	41645	41708	41772	41835	41899	41962	42026	42090	42153	42217	740
750	42281	42344	42408	42472	42536	42599	42663	42727	42791	42855	750
760	42919	42983	43047	43111	43175	43239	43303	43367	43431	43495	760
770	43559	43624	43688	43752	43817	43881	43945	44010	44074	44139	770
780	44203	44267	44332	44396	44461	44525	44590	44655	44719	44784	780
790	44848	44913	44977	45042	45107	45171	45236	45301	45365	45430	790
800	45494	45559	45624	45688	45753	45818	45882	45947	46011	46076	800
810	46141	46205	46270	46334	46399	46464	46528	46593	46657	46722	810
820	46786	46851	46915	46980	47044	47109	47173	47238	47302	47367	820
830	47431	47495	47560	47624	47688	47753	47817	47881	47946	48010	830
840	48074	48138	48202	48267	48331	48395	48459	48523	48587	48651	840
850	48715	48779	48843	48907	48971	49035	49099	49162	49226	49290	850
860	49353	49417	49481	49544	49608	49672	49735	49799	49862	49926	860
870	49989	50052	50116	50179	50243	50306	50369	50432	50495	50559	870
880	50622	50685	50748	50811	50874	50937	51000	51063	51126	51189	880
890	51251	51314	51377	51439	51502	51565	51627	51690	51752	51815	890
900	51877	51940	52002	52064	52127	52189	52251	52314	52376	52438	900
910	52500	52562	52624	52686	52748	52810	52872	52934	52996	53057	910
920	53119	53181	53243	53304	53366	53427	53489	53550	53612	53673	920
930	53735	53796	53857	53919	53980	54041	54102	54164	54225	54286	930
940	54347	54408	54469	54530	54591	54652	54713	54773	54834	54895	940
950	54956	55016	55077	55138	55198	55259	55319	55380	55440	55501	950
960	55561	55622	55682	55742	55803	55863	55923	55983	56043	56104	960
970	56164	56224	56284	56344	56404	56464	56524	56584	56643	56703	970
980	56763	56823	56883	56942	57002	57062	57121	57181	57240	57300	980
990	57360	57419	57479	57538	57597	57657	57716	57776	57835	57894	990
1000	57953	58013	58072	58131	58190	58249	58309	58368	58427	58486	1000
1010	58545	58604	58663	58722	58781	58840	58899	58957	59016	59075	1010
1020	59134	59193	59252	59310	59369	59428	59487	59545	59604	59663	1020
1030	59721	59780	59838	59897	59956	60014	60073	60131	60190	60248	1030
1040	60307	60365	60423	60482	60540	60599	60657	60715	60774	60832	1040
1050	60890	60949	61007	61065	61123	61182	61240	61298	61356	61415	1050
1060	61473	61531	61589	61647	61705	61763	61822	61880	61938	61996	1060
1070	62054	62112	62170	62228	62286	62344	62402	62460	62518	62576	1070
1080	62634	62692	62750	62808	62866	62924	62982	63040	63098	63156	1080
1090	63214	63271	63329	63387	63445	63503	63561	63619	63677	63734	1090
1100	63792	63850	63908	63966	64024	64081	64139	64197	64255	64313	1100
1110	64370	64428	64486	64544	64602	64659	64717	64775	64833	64890	1110
1120	64948	65006	65064	65121	65179	65237	65295	65352	65410	65468	1120
1130	65525	65583	65641	65699	65756	65814	65872	65929	65987	66045	1130
1140	66102	66160	66218	66275	66333	66391	66448	66506	66564	66621	1140
1150	66679	66737	66794	66852	66910	66967	67025	67082	67140	67198	1150
1160	67255	67313	67370	67428	67486	67543	67601	67658	67716	67773	1160
1170	67831	67888	67946	68003	68061	68119	68176	68234	68291	68348	1170
1180	68406	68463	68521	68578	68636	68693	68751	68808	68865	68923	1180
1190	68980	69037	69095	69152	69209	69267	69324	69381	69439	69496	1190
1200	69553										1200

Type J Thermocouple Table

Iron/Copper-Nickel, Electromotive force as a function of temperature

		$E/\mu\text{V}$									
$t_{90}/^{\circ}\text{C}$	0	-1	-2	-3	-4	-5	-6	-7	-8	-9	$t_{90}/^{\circ}\text{C}$
-210	-8095										-210
-200	-7890	-7912	-7934	-7955	-7976	-7996	-8017	-8037	-8057	-8076	-200
-190	-7659	-7683	-7707	-7731	-7755	-7778	-7801	-7824	-7846	-7868	-190
-180	-7403	-7429	-7456	-7482	-7508	-7534	-7559	-7585	-7610	-7634	-180
-170	-7123	-7152	-7181	-7209	-7237	-7265	-7293	-7321	-7348	-7376	-170
-160	-6821	-6853	-6883	-6914	-6944	-6975	-7005	-7035	-7064	-7094	-160
-150	-6500	-6533	-6566	-6598	-6631	-6663	-6695	-6727	-6759	-6790	-150
-140	-6159	-6194	-6229	-6263	-6298	-6332	-6366	-6400	-6433	-6467	-140
-130	-5801	-5838	-5874	-5910	-5946	-5982	-6018	-6054	-6089	-6124	-130
-120	-5426	-5465	-5503	-5541	-5578	-5616	-5653	-5690	-5727	-5764	-120
-110	-5037	-5076	-5116	-5155	-5194	-5233	-5272	-5311	-5350	-5388	-110
-100	-4633	-4674	-4714	-4755	-4796	-4836	-4877	-4917	-4957	-4997	-100
-90	-4215	-4257	-4300	-4342	-4384	-4425	-4467	-4509	-4550	-4591	-90
-80	-3786	-3829	-3872	-3916	-3959	-4002	-4045	-4088	-4130	-4173	-80
-70	-3344	-3389	-3434	-3478	-3522	-3566	-3610	-3654	-3698	-3742	-70
-60	-2893	-2938	-2984	-3029	-3075	-3120	-3165	-3210	-3255	-3300	-60
-50	-2431	-2478	-2524	-2571	-2617	-2663	-2709	-2755	-2801	-2847	-50
-40	-1961	-2008	-2055	-2103	-2150	-2197	-2244	-2291	-2338	-2385	-40
-30	-1482	-1530	-1578	-1626	-1674	-1722	-1770	-1818	-1865	-1913	-30
-20	-995	-1044	-1093	-1142	-1190	-1239	-1288	-1336	-1385	-1433	-20
-10	-501	-550	-600	-650	-699	-749	-798	-847	-896	-946	-10
0	0	-50	-101	-151	-201	-251	-301	-351	-401	-451	0

9.4 GENERAL THERMOMETRY DATA AND OTHER REFERENCE INFORMATION

9.4.1. Temperature Conversion Table °C / °F

Centigrade to Fahrenheit					
to C	F/C	to F	to C	F/C	to F
-184.4	-300	-508.0	593.3	1100	2012.0
-156.7	-250	-418.0	621.1	1150	2102.0
			648.9	1200	2192.0
-128.9	-200	-328.0	676.7	1250	2282.0
-101.1	-150	-238.0	704.4	1300	2372.0
- 73.3	-100	-148.0	732.2	1350	2462.0
- 45.6	- 50	- 58.0	760.0	1400	2552.0
- 17.8	0	32.0	787.8	1450	2642.0
10.0	50	122.0	815.6	1500	2732.0
37.8	100	212.0	843.3	1550	2822.0
65.6	150	302.0	871.1	1600	2912.0
93.3	200	392.0	898.9	1650	3002.0
121.1	250	482.0	926.7	1700	3092.0
148.9	300	572.0	954.4	1750	3182.0
176.7	350	662.0	982.2	1800	3272.0
204.4	400	752.0	1010.0	1850	3362.0
232.2	450	842.0	1037.8	1900	3452.0
260.0	500	932.0	1065.6	1950	3542.0
287.8	550	1022.0	1093.3	2000	3632.0
315.6	600	1112.0	1121.1	2050	3722.0
343.3	650	1202.0	1148.9	2100	3812.0
371.1	700	1292.0	1176.7	2150	3902.0
398.9	750	1382.0	1204.4	2200	3992.0
426.7	800	1472.0	1232.2	2250	4082.0
454.4	850	1562.0	1260.0	2300	4172.0
482.2	900	1652.0	1287.8	2350	4262.0
510.0	950	1742.0	1315.6	2400	4352.0
537.8	1000	1832.0	1343.3	2450	4442.0
565.6	1050	1922.0			

9.4.2. Fixed Temperature Points

Materials exist in different states (phases), liquid, solid or gas according to their temperature. At certain specific temperatures, two or three phases can occur simultaneously. In water for example, the three phases can exist together at the **triple point** (0.01°C). Triple points are unusual and most materials exhibit only two coincident phases.

Other fixed points are the freezing points of pure metals. As a molten metal is cooled, the melt begins to solidify at a certain temperature depending on the particular metal. The change from liquid to solid does not occur suddenly and, during this change of phase the temperature remains constant until the metal has entirely solidified. This freezing point temperature value depends only on the degree of purity of the metal; knowledge of this temperature and the facility to achieve it provides a highly accurate and absolutely reproducible temperature reference.

9.4.3. International Temperature Scale ITS-90

The temperature values of the fixed points are determined with devices suitable for measuring thermodynamic temperatures such as gas thermometers. Discussion between the various National laboratories has resulted in the official adoption of certain fixed points internationally as **primary temperatures**. Intermediate values on the resulting temperature scale are defined by interpolation. The scale thus established has practical application in science and industry using commercially available calibrated, high precision platinum resistance thermometers.

The development of the more accurate ITS-90 which replaces the IPTS-68 defines the following fixed points:

Equilibrium state

Triple point of hydrogen	-259.3467°C
Boiling point of hydrogen at a pressure of 33321.3 Pa	-256.115°C
Boiling point of hydrogen at a pressure of 101292 Pa	-252.88°C
Triple point of neon	-248.5939°C
Triple point of oxygen	-218.7916°C
Triple point of argon	-189.3442°C
Triple point of mercury	-38.8344°C
Triple point of water	0.01°C
Melting point of gallium	29.7646°C
Freezing point of indium	156.5985°C
Freezing point of tin	231.928°C
Freezing point of zinc	419.527°C
Freezing point of aluminium	660.323°C
Freezing point of silver	961.78°C
Freezing point of gold	1064.18°C
Freezing point of copper	1084.62°C

ITS-90, like IPTS-68 is based on the SI units of temperature, the Kelvin and the degree Celcius. The ITS-90 allows for a more accurate realisation of temperature standards and their use in industry, particularly in the important high temperature region. The differences between ITS-90 and IPTS-68 are shown in Fig. 58.

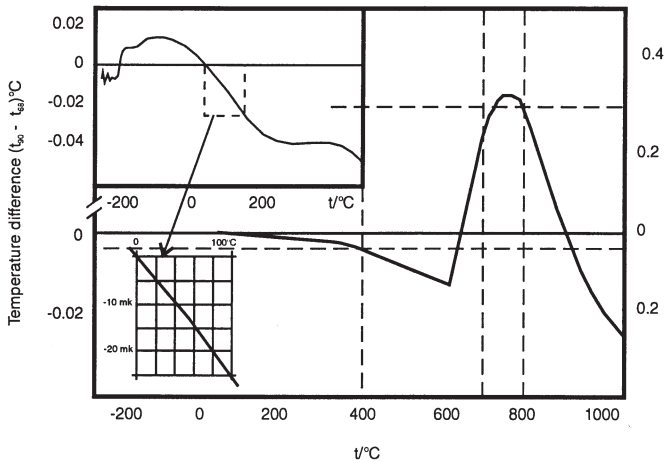

Fig 58: Differences between ITS-90 and IPTS-68, $(t_{90} - t_{68})/^{\circ}\text{C}$

9.4.4. Grades of Protection for Enclosures

The grades of protection for enclosures containing apparatus are defined in BS 4752. The type of protection is defined by two digits, the first relating to accessibility and the second to environmental protection. The two numbers are preceded by the letters IP.

First Number	Degree of Protection	Second Number	Degree of Protection
0	No protection of persons against contact with live or moving parts inside the enclosure	0	No protection
1	Protection against accidental or inadvertent contact with live or moving parts inside the enclosure by a large surface of the human body, for example, a hand, but not protection against deliberate access to such parts Protection against ingress of large solid foreign bodies.	1	Protection against drops of condensed water. Drops of condensed water falling on the enclosure shall have no harmful effect.
2	Protection against contact with live or moving parts inside the enclosure by fingers. Protection against ingress of medium size solid foreign bodies.	2	Protection against drops of liquid. Drops of falling liquid shall have no harmful effect when the enclosure is tilted at any angle up to 15° from the vertical.
		3	Protection against rain. Water falling in rain at an angle up to

3	Protection against contact with live or moving parts inside the enclosure by tools, wires or such objects of thickness greater than 2.5mm. Protection against ingress of small solid foreign bodies.		60° with respect to the vertical shall have no harmful effect.
4	Protection against contact with live or moving parts inside the enclosure by tools, wires or such objects of thickness greater than 1mm. Protection against ingress of small foreign bodies.	4	Protection against splashing. Liquid splashed from any direction shall have no harmful effect.
5	Complete protection against contact with live or moving parts inside the enclosure. Protection against harmful deposits of dust. The ingress of dust is not totally prevented, but dust cannot enter in any amount sufficient to interfere with satisfactory operation of the equipment enclosed.	5	Protection against water-jets. Water projected by a nozzle from any direction under stated conditions shall have no harmful effect.
6	Complete protection against contact with live or moving parts inside enclosure. Protection against ingress of dust.	6	Protection against conditions on ships decks (deck watertight equipment). Water from heavy seas shall not enter the enclosure under prescribed conditions.
		7	Protection against immersion in water. It must not be possible for water to enter the enclosure under stated conditions of pressure and time.
		8	Protection against indefinite immersion in water under specified pressure. It must not be possible for water to enter the enclosure.

Zener safety barriers are normally located in the safe area and must of themselves be or be contained in an enclosure giving protection of at least IP20.

9. 4.5. Problem Solving in Temperature Measurement & Control Using Thermocouples or Resistance Thermometers

Indicator/ Controller/ Symptom	Likely causes in the Case of Thermocouple Sensing	Likely Cause in the Case of Resistance Thermometer Sensing
Ambient indication	Sensor not in the process. Thermocouple or extension cable shorting out. Process temperature low (no heating applied)	Sensor not in the process Process temperature low (No heating applied)
Erratic (noisy) indication	RF or mains noise pick-up. Poor connection in sensor circuit. Faulty instrument.	RF or main noise pick-up. Poor connection in sensor circuit. Faulty instrument.
Indication high	Process temperature high. Instrument calibration error. Incorrect thermocouple used. Incorrect extension cable used. Reversed cable connection at thermocouple and instrument.	Process temperature high. High resistance in 2 wire sensor circuit. Excessive excitation current in sensor causing self-heating. Note: Use 3 or 4 wire input if possible. Instrument calibration error. Contaminated sensing element.
Indication Low	Instrument calibration error. Incorrect thermocouple used. Incorrect extension cable used.	Instrument calibration error. Sensor fault.
Up- Scale indication	Process temperature very high. Thermocouple open circuit. To check instrument: disconnect sensor from input terminals and replace with a link. If ambient temperature is indicated, fault is in sensor circuit.	Process temperature very high. Sensor is open circuit. To check instrument: disconnect sensor from input terminals and replace with 100 Ohm resistor. If 0°C is indicated, fault is in sensor circuit.
Down-Scale indication	Process temperature very low. Thermocouple shorted out. Thermocouple connection reversed. Check instrument as above.	Process temperature very low. Sensor shorted out. Check instrument as above.
Indicator error	Instrument or sensor out of calibration. Incorrect cable used. Reversed cable connection at thermocouple and instrument.	Instrument or sensor out of calibration Additional resistance in 2 wire sensor circuit. If offset positive sensor excitation current rather high causing slight self-heating.
Indicator reading drift	Instrument calibration drift. Aged or faulty thermocouple - common with base metal types after long period of service. Incorrect cable used.	Instrument calibration drift. Excessive excitation current in sensor causing self-heating.

Indication correct magnitude but negative	Reversed polarity at thermocouple input connection.	N/A
Reading obtained with one input wire disconnected.	Electrical / r.f. pick-up on sensor wires due to induction or damp insulation.	Electrical / r.f. pick-up on sensor wires due to induction or damp insulation.
Sloppy/poor control	PID terms incorrect. Sensor remote from source of heating in process	PID terms incorrect. Sensor remote from source of heating in process.
Full heating applied continuously (unregulated)	Controller or power switch fault. Thermocouple connection reversed (downscale reading). Thermocouple shorted out.	Controller or power switch fault. Sensor shorted out.
No heating power	Controller or power switch fault. Thermocouple open circuit	Controller or power switch fault. High resistance in sensor circuit (upscale reading).
Measurement errors in multi-channel installation (e.g. multi-zone junctions) control, scanners, recorders.	Electronic switching fault. Earth loops established in thermocouple circuits (common with non-insulated thermocouple use of insulated versions should eliminate or reduce this effect.)	Electronic switching fault. Sensors energised in sequence can result in this effect. Usually non resistance thermometers in series. Refer to instrument instructions for guidance.

9.4.6. International and National Standard Specifications

The items listed are those most commonly utilised in practical thermometry and the list is not complete; no responsibility can be accepted for current validity or otherwise. It is essential that the user checks with the relevant National body in each case.

International harmonised standards

IEC 65B (CO) 76 (1989)

Base metal insulated thermocouple cables and thermocouples (draft)

IEC 584-1:1995

Thermocouples, Reference tables

IEC 584-2:1982

Thermocouples, Tolerances

IEC 584-3:1989

Extension and compensating cables. Tolerances and identification system.

IEC 654-1 (1979)

Operating conditions for industrial-process measurement and control equipment. Part 1: Temperature, humidity and barometric pressure

IEC 751:1983

Industrial platinum resistance thermometer sensors

American Standards

ASTM E 220 (1986)

Methods for calibration of thermocouples by comparison techniques

ASTM E 230 (1987)

Temperature electromotive force (EMF) tables for standardised thermocouples

ASTM E 585 (1988)

Specification for sheathed base-metal thermocouple materials

ASTM E 644 (1986)

Method for testing industrial resistance thermometers

ASTM E 1129 (1986)

Thermocouple connectors

ASTM E 1137 (1987)

Specification for industrial platinum resistance thermometers

ASTM E 1159 (1987)

Specification for thermocouple materials, platinum-rhodium alloy and platinum

ASTM E 1223 (1987)

Specification for Type N thermocouple wire

NEMA WC-55 (1986)

Instrumentation cables and thermocouple wire (includes thermocouple extension cables)

Australian Standards

AS 2091 (1981)

Resistance thermometers and their elements (platinum, copper, nickel)

British Standards

BS 1041

Temperature measurement

Part 3 (1989) Guide to the selection and use of industrial resistance thermometers

Part 4 (1992) Guide to the selection and use of thermocouples

BS 4937-30:1993

Colour code for twin compensating cables for thermocouples

BS EN 60751:1996

Specification for industrial platinum resistance thermometer sensors

BS 2765 (1969, 1981)

Specification for dimensions of temperature detecting elements and corresponding pockets

BS EN 60584-1:1996

International thermocouple reference tables, Parts 1-8, 20

BS EN 60584-2:1993

Specifications for thermocouple tolerances

BS 6175 (1982)

Specification for temperature transmitters with electrical outputs

French Standards

NF C 42-321 (1987)

Electrical measuring instruments – Thermocouples – Reference tables

NF C 42-322 (1987)

Electrical measuring instruments – Tolerances

NF C 42-323 (1985)

Electrical measuring instruments – Identification of thermocouples

NF C 42-324 (1985)

Electrical measuring instruments – compensating cables for thermocouples

NF C 42-325 (1987)

Sheathed cables

NF C 42-330 (1983)

Electrical measuring instruments – Platinum resistance temperature sensors – Reference tables and tolerances.

German Standards

DIN 43 710 (1985)

Reference tables type U and type L for thermocouples

DIN 43 712 (1987)

Wires for thermocouples

DIN 43 714 (1990)

Compensating cables for thermocouple thermometers

DIN 43 720 (1990)

Metal protective tubes for thermocouples

DIN 43 721 (1980)

Mineral insulated thermocables and mineral insulated thermocouples

DIN 43 724 (1979)

Ceramic protection tubes and holding rings for thermocouple thermometers

DIN 43 725 (1990)

Refractory insulating tubes for thermocouples

DIN 43 729 (1979)

Connecting heads for thermocouple thermometers and resistance thermometers

DIN 43 732 (1986)

Thermocouples for thermocouple thermometers

DIN 43 733 (1986)

Straight thermocouple thermometers without interchangeable sensor units

DIN 43 735 (1986)

Sensor units for thermocouple thermometers

VDE/VDI 3511 (1967)

Technical temperature measurement

10. GLOSSARY OF TERMS

10.1 ABBREVIATIONS AND ACRONYMS FOR STANDARDS & STANDARDS BODIES

ANSI	American National Standards Institute
ASTM	American Society for Testing and Materials
BASEEFA	Health and Safety Executive Standard on Plant safety
BSI	British Standards Institution
BS	British Standards Institution Standards
CEN	European Committee for Standardisation
CENELEC	European Committee for Electrical Standardisation
DIN	Deutsche Institut fur Normung
ELSECOM	European Electrotechnical Sectoral Committee for Testing and Certification
EN	CEN/CENELEC European Standards
EOTC	European Organisation for Testing and Certification
GAMBICA	The Association for the Instrumentation, Control and Automation Industry in the UK.
IEC	International Electrotechnical Commission
IEEE	IEEE Standards
IPTS-68	International Practical Temperature Scale of 1968
ISO	International Organisation for Standardisation
ITS-90	International Temperature Scale of 1990
NAMAS	EEC listed Certification Bodies/Accreditation Service
NBS	National Bureau of Standards, USA
NPL	National Physical Laboratory, UK
UKAS	United Kingdom Accreditation Service

10.2 CALIBRATION

Calibration	Checking/ measuring accuracy against an external reference/standard
Calibrator	Device used for or in calibration
Drift	Change in the value of a parameter due to operational influence (e.g. temperature variation / ageing)
Dry Block Calibrator	A thermal device which does not use a fluid medium as a temperature source
Fixed Points (Temperature)	Temperatures defined by physical laws, change of state of pure materials
Fixed Point Cell	A device used to provide a fixed point temperature
Primary Standards	Those derived from the best available equipment. Pertaining to establishing the International Temperature Scale.
Reference Probe	Certified probe used as a comparison standard

Secondary Standard	Traceable to primary Standards
Simulator	Instrument which produces electrical signals emulating those of sensors
Standard Resistance Thermometer	A laboratory standard probe for the highest possible accuracy of measurement
Stirred Liquid Bath	A controlled thermal reference which uses a stirred liquid medium
Temperature Calibration Point	A temperature value at which calibration is performed by comparison or direct techniques
Thermal Calibration	Calibration using a temperature source (i.e. not electrical)
Thermal Reference	Controlled temperature source
Tolerances	Stated uncertainties
Triple Point of Water	A thermodynamic state (of water) in which the gas, liquid and solid phases all occur in equilibrium. Value 0.01°C
Uncertainties	Possible inaccuracies

10.3 CONTROL

Auto-manual	Selection of closed loop (automatic) or open loop (manual) regulation
Auto-tune	Automatic selection of the control terms, usually P,I and D
Bumpless Transfer process	Permits switching from manual to automatic control without disturbances due to integral saturation
Calibration	Checking/measuring accuracy against an external reference or standard
Closed Loop	Automatic control via feedback
Cold Junction Compensation (Automatic)	Built-in, automatic compensation for ambient temperature variations when using a thermocouple sensor
Controller	The instrument which provides automatic measurement and control of a process
Control Output	The means of controlling energy regulation in the process
D	Abbreviation of Derivative
Dead-band	On-Off hysteresis to prevent excessively rapid power switching
Derivative Time Constant	A measure of Derivative term sensitivity

Hysteresis	Dead-band defined in on-off switching
I	Abbreviation of Integral
Integral Time	Summation period for offset computation
Offset	Difference between set-point and resultant control point
On-Off	Power regulation by simple on-off switching (e.g. thermostat)
Open Loop	System not utilising feedback (i.e. not capable of automatic control)
Output	Control signal or communication data
Overshoot	The amount by which the process temperature exceeds set-point on start-up
P	Abbreviation of proportional
Process	The system being monitored or controlled
Process Variable	The parameter monitored or controlled
Proportional Band	The control band within which power is regulated between 0 and 100% usually express as a percentage of the overall temperature range
Set-point	Desired process temperature set by the operator
Start-up	Dynamic state of the process after switching on
Thermal Mass	Heat storage effect in the process
Three Term	Defines P,I and D control action
Tuning	Optimising P,I and D terms to achieve good control. Can be manual or automatic

10.4 INSTRUMENTATION – GENERAL

Alternating Current (ac)	Electric current which alternates in direction. The number of times the current changes direction in one second is called the frequency.
Amplifier	A device which produces a larger output signal than is applied at its input.
Analogue-to-digital (A-D) Converter	Converts an analogue signal (such as a voltage signal from a temperature sensor) into a digital signal suitable for input to a computer.
ASCII	American Standard Code for Information Interchange. Coding for text files.
Batch Process	Any process on which operations are carried out on a limited number of items as opposed to continuous process.

CE	Conformite Europeene. A mark that is affixed to a product to designate that it is in full compliance with all applicable European Union legal requirements.
Closed Loop	Facility for automatic control by means of temperature feedback from the process to the instrument
Common-Mode Signal	A signal applied simultaneously to both inputs of a device.
Common-Mode Rejection Ratio (cmrr)	The ability of the device to obtain the difference between the + and – inputs whilst rejecting the signal common to both.
Comms	Abbreviation of Communications interface
Contact emf	Electromotive force which arises at the point of contact metals.
Control	Regulation of process energy to achieve a desired temperature
Data Acquisition	Gathering data from a process, usually electronic, usually automatic
DAU	Abbreviation of Data Acquisition Unit
Direct Current (dc)	Current which flows in one direction.
Electromotive Force (emf)	Difference of potential (V) produced by sources of electrical energy which can be used to drive currents through external circuits.
Excitation	The operational voltage or current applied to a transducer.
Filtering	Attenuates components of undesired signal
Frequency	Measured in Hertz (cycles per second), rate of repetition of changes.
Full Scale Output	The difference between the minimum output (normally zero) of a device and the rated capacity (full signal).
Gain	Amplification of a circuit.
Ground	Connection to ground (earth).
HART	Highway Addressable Remote Terminal. Provides digital communication to microprocessor-based (smart) analogue process control instruments.
Hertz (Hz)	Cycles per second unit of frequency.
Indication	Analogue or digital readout of data
Input	The connection point for a sensor or defines type of sensor
I/O	Input/Output. A measuring system monitors signal through its inputs and sends control signals through its outputs.

Isolation	Electrically isolated condition
Linearisation	Matching the transfer characteristic of the sensor if non-linear (strictly de-linearisation)
Logging	Recording data
Noise	Any unwanted electrical signals affecting the signal to be measured.
Non-linear	Not a straight line transfer characteristic
Open Loop	System not utilising feedback
Output	Data exiting a device
PC	Personal Computer. Generally applied to computers conforming to the IBM designed architecture.
Pick-up	Superimposition of unwanted electrical signals in the system (usually high frequency and/or high voltage)
PID	Proportional gain, integral action time and derivative action time.
Port	The external connector of a device.
Positive Temperature Coefficient	An increase in resistance due to an increase in temperature.
Process	The system being monitored
Protocol	A set of rules used in data communications.
QA	Quality Assurance
Range	Full-scale signal (input or output).
Relay	Electromechanical device that opens or closes contacts when a current is passed through its coil.
Resolution	A measure of the smallest detectable change.
Repeatability	The ability of an instrument to repeatedly give the same reading.
r.f.i.	Abbreviation of radio frequency interference
SCADA	Abbreviation of Supervisory Control and Analogue Data Acquisition
Scan	Reading each input channel in turn. The scan will return to the first channel once all the channels have been sampled.
Seebeck Effect	The thermocouple principle. In a circuit in which there are junctions between dissimilar metals, an electromotive force (voltage) is set up when the junctions are at different temperatures.

Sensitivity	A measure of the minimum change in an input signal that an instrument can detect.
Sensor	A device that can detect a change in a physical quantity and produce a corresponding electrical signal.
Serial Communication	Where data is transferred one bit at a time.
Settling Time	When a change in signal occurs, the time taken for the input or output channel to settle to its new value.
SI	International system of units. Abbreviation for Systeme International (d'Unites).
Signal Conditioning	Changing the electrical characteristics of a sensor signal
Stability	The ability of an instrument to maintain a consistent output with the application of a constant input
System	Combination of several circuits or items of equipment to perform in a particular manner.
Temperature Coefficient of...	Amount by which a parameter varies due to temperature
Thermal Conductivity	A measure of the rate of flow of thermal energy through a material in the presence of a temperature gradient. Materials with high electrical conductivities usually have high thermal conductivities.
Transient	A short duration surge of current or voltage.
Transmitter	A device for amplifying a sensor signal in order to permit its transmission to remote instrumentation. Usually converts to 4-20mA

10.5 THERMOMETRY – GENERAL

Absolute Zero	The lowest possible temperature of a body due to absence of molecular motion. Stated as 0 Kelvin, equivalent to -273.15°C
Alpha	The temperature coefficient of resistance of a sensing resistor. Expressed as W/°C
Alumina	Aluminium Oxide (a refractory material)
Barrier Terminal	Terminal block configuration
Base Metal Thermocouple	Thermocouple utilising base metals
Boiling Point	The equilibrium temperature between a liquid and its vapour
Callendar – Van Dusen Equation	An interpolation equation which provides resistance values as a function of temperature for sensing resistors

Ceramic	Refractory insulating material
Coefficients (ABC)	Used in the Pt100 characteristic polynomial; they define the temperature – resistance relationship
Cold junction	Reference junction of a thermocouple
Cold Junction Compensation (CJC)	Compensation for thermocouple reference junction temperature variations
Colour Codes	Means of cable and sensor type identification; applied internationally according to appropriate standards
Compensating Cable	Used for connecting thermocouples to instruments; the conductors use low cost materials which have a similar ambient thermal emf relationship to that of the thermoelement but at lower cost
Compression Fitting	Type of threaded fitting which compresses on to the probe sheath to provide a pressure tight coupling
Cryogenic	A term for very low temperatures, usually associated with liquified gases
Drift	Change in the value of a parameter due to operational influence (e.g. temperature variation / ageing)
Excitation Current	Current supplied to an appropriate sensor or transducer to provide excitation
Exposed Junction	A thermojunction not protected by sheath material. Used when fast thermal response is required
Extension Cable	Thermocouple connecting cable which uses conductors in true thermocouple alloy
Fabricated	Made from component parts e.g. a thermocouple assembly made from tubing, wire and insulating materials as opposed to one made using mineral insulated cable
Fittings	Items used to secure probes into machinery e.g. compression glands, threaded bushes, bayonet fittings
Fixed Points (Temperature)	Temperatures defined by physical laws, change of state of pure materials
Flange	Form of disc through which probe is installed into a process
Freezing Point	The fixed temperature point of a material which occurs during the transition from a liquid to solid state. Also known as Melting Point for pure materials.
Fundamental Interval	Thermometer resistance change over the range 0 to 100°C

Grounded Hot Junction	Thermocouple configuration in which the thermoelement is electrically common to the sheath
Hot Junction	Measuring junction of thermocouple
Ice Point	0°C
Immersion	Placing of probe into the process medium (i.e. immersion into some medium)
Insert	Replaceable probe assembly located inside outer sheath
Insulation Resistance	Value of resistance measured between the sensor wire and sheath
Interchangeability	Describes how closely a sensor adheres to its defining equation
Isothermal	Equal temperature
Lagging Extension	Probe or pocket extension to allow for thickness of pipe or wall lagging
Leg	Common term for one thermoelement wire in a thermocouple circuit
Linearity	A deviation in response from straight line value of a sensor
Loop Resistance	The total resistance of a thermocouple circuit
Measuring Junction	Thermoelement measuring junction (hot junction)
Melting Point	The temperature at which a substance converts from the solid to liquid phases. This is the same as the Freezing Point for pure materials
Metallic	Pertaining to presence of metal in sheath material as opposed to non-metallic
MI	Abbreviation for Mineral Insulated as used in sensor cable
Mineral Insulated	Type of cable construction used in thermometry. Conductors are insulated from sheath by compressed refractory oxide powder.
Noble Metal t/c	Rare metal, usually Platinum / Rhodium alloys
Noise	Unwanted electrical interference picked up on a signal cable
NTC	Negative temperature coefficient (of resistance)
Parallel Pair	Wire construction where two single conductors are laid parallel
Platinum Resistance Thermometer (PRT)	Platinum temperature sensor whose resistance varies with temperature

Polarity	Determines the direction of current flow in an electrical circuit
Protection Tube	A tube (sheath) which protects a sensor from its operating environment
PTC	Positive temperature coefficient (of resistance)
Rare Metal t/c	Thermocouple made of rare metal thermoelement
Reference Junction	Of the thermocouple, usually referred to the ice point
Resistance	Temperature sensor, usually Platinum, whose resistance varies with Thermometer temperature
Response Time	A measure of thermal sensitivity applied to sensors. The time required for a sensor to reach 63% of the step change in temperature under particular conditions
Ro	The value of thermometer resistance temperature sensors at 0°C
RTD	Abbreviation for resistance temperature detector
Self-heating	Heating effect due to current flow in the sensing resistor of a resistance thermometer
Sensing Length	That portion of the probe sensitive to temperature
Sensing Resistor	The sensing element of a resistance thermometer
Stability	The ability of a sensor to maintain a constant output with the application of a constant input
Stem Conduction	The flow of heat away from the sensing length of a probe due to probe thermal conductivity
Stem Sensing	Sensing over a finite length of sheath as opposed to just the tip
Tails	Connecting wires emanating from the sensor
Thermal Conductivity	The ability of a material to conduct heat
Thermal Gradient	The distribution of different temperatures in and across an object
Thermal Mass	Heat storage effect in the process
Thermistor	A form of resistance thermometer, usually a NTC type.
Thermocouple	Temperature sensor based on a thermoelement
Thermocouple Type	Defines the type of thermoelement e.g. J,K,T,E,N,R,S,B etc.
Thermoelectric	Electrical activity resulting from the generation of thermo-voltages

Thermoelement	The two dissimilar conductors and their junction forming a thermocouple
Thermojunction	The junction formed between the dissimilar conductors of a thermocouple. Usually describes the measuring junction
Thermowell	Used to protect sensor probes against aggressive media. Effectively a pocket or well in the process into which the probe is inserted
Thin Film	Sensing resistor in a thin film form
Tip Sensing	Temperature sensing at the tip of a probe only as opposed to along its length
Transducer	A device which converts energy from one form into another. Transducer often describes a sensor
Transfer Function	Input/Output characteristic of a device
Transmitter	A device for amplifying a sensor signal in order to permit its transmission to remote instrumentation. Usually converts to 4-20mA
Twisted Pair	Two insulated conductors twisted together. Twisted wires in thermocouple circuits minimise noise pick-up
Wheatstone Bridge	A network of four resistances, an emf voltage source, and an indicator connected such that when the four resistances are matched, the indicator will show a zero deflection or "null" reading. Prototype of most other bridge circuits.
Wirewound	Sensing resistor in wirewound construction

11. ACKNOWLEDGEMENTS AND REFERENCES

Temperature Sensing with Thermocouple and Resistance Thermometers – A Practical Handbook (2nd Edition. 1982) LABFACILITY LTD

The International Temperature Scale of 1990. NATIONAL PHYSICAL LABORATORY HMSO

Reference Manual for Temperature Products and Services. 1995. ISOTHERMAL TECHNOLOGY LTD

Temperature by T.J. Quinn (Monographs in Physical Measurement) 1983. ACADEMIC PRESS

Manual on the use of Thermocouples in Temperature Measurement. AMERICAN SOCIETY FOR TESTING AND MATERIALS 1916, RACE STREET, PHILADELPHIA PA. 19103, USA.

Temperature Measurement in Engineering Vols 1 and 2. OMEGA PRESS, ONE OMEGA DRIVE, BOX 4047, STAMFORD, CONNECTICUT 06907, USA.

SPECIAL ACKNOWLEDGEMENT

The tables of thermocouple and Pt100 characteristics in Chapter 10 are reproduced with the kind permission of Isothermal Technology Ltd; Southport UK, who also supplied some of the photographs shown in Chapter 6.

12. FREQUENTLY ASKED QUESTIONS

Remember, the sensor type must always suit the measuring instrument and employ the correct extension cable. Information given here is for general guidance only and is not definitive – it is not intended to be the basis for product installation or decision making. Labfacility Ltd can not be held responsible for any misinterpretation or incorrect assumptions based on these Questions and Answers.

1. What is the difference between a Mineral Insulated (MI) and a fabricated sheath?

A. An MI is flexible, a fabricated sheath is rigid.

2. How accurately can I measure temperature using a standard sensor?

A. To published, internationally specified tolerances as standard, typically $\pm 2.5^{\circ}\text{C}$ for popular thermocouples, $\pm 0.5^{\circ}\text{C}$ for PRT. Higher accuracy sensors can be supplied to order, e.g. $\pm 0.5^{\circ}\text{C}$ for type T thermocouple, $\pm 0.2^{\circ}\text{C}$ for PRT. All of these values are temperature dependent. A close tolerance, 4-wire PRT will give best absolute accuracy and stability.

3. How do I choose between a thermocouple and a PRT?

A. Mainly on the basis of required accuracy, probe dimensions, speed of response and the process temperature.

4. My thermocouple is sited a long way from my controller, is this a problem?

A. It could be; try to ensure a maximum sensor loop resistance of 100 Ohms for thermocouples and 4-wire PRTs. Exceeding 100 Ohms could result in a measurement error. Note By using a 4-20mA transmitter near the sensor, cable runs can be much longer and need only cheaper copper wire. The instrument must be suitable for a 4-20mA input though.

5. What is the difference between a RTD and PRT sensor?

A. Nothing. RTD means resistance thermometer detector (the sensing element) and PRT means Platinum resistance thermometer (the whole assembly) i.e. a PRT uses a RTD!

6. What is a Pt100?

A. An industry standard Platinum RTD with a value of 100 Ohms @ 0°C to IEC751; this is used in the vast majority of PRT assemblies in most countries.

7. Should I choose a Type K or Type N thermocouple?

A. Generally, Type N is more stable and usually lasts longer than Type K; N is a better choice for high temperature work depending on the choice of sheath material.

8. Does it matter what type of steel I specify for the thermocouple sheath?

A. Often no, sometimes yes. In some cases, reliability depends on the ideal choice of material.

9. Are there other types of temperature sensor apart from thermocouple and PRT Types?

A. Several, but these two groups are the most common. Alternatives include thermistors, infra-red (non-contact), conventional thermometers (stem & dial types) and many others.

10. Why are so many different types of thermocouple used?

A. They have been developed over many years to suit different applications world-wide.

11. What is a duplex sensor?

A. One with two separate sensors in a single housing

12. Why use a thermowell?

A. To protect the sensor from the process medium and to facilitate its replacement if necessary.

13. I use many thermocouples in testing and experiments, can I make my own thermocouple junctions?

A. Yes, using a benchtop welder and fine thermocouple wires – it is easy and inexpensive to make unsheathed thermocouples.

14. Why should I use actual thermocouple connectors instead of ordinary electrical connectors?

A. Good quality thermocouple connectors use thermocouple alloys, polarized connections and colour coded bodies to guarantee perfect, error-free interconnections.

15. Why offer 2,3 or 4 wire PRT probes?

A. Because all 3 are encountered. Two-wire should be avoided, three-wire is widely used and four-wire gives optimum accuracy. Your instrument will be configured for 2,3 or 4 wire.

16. For thermocouple cable and connectors, why are there two colours available for the same calibration?

A. Since December 1998, the International colour code to IEC 60584-3 should be observed.

17. I need to measure quickly changing temperature; what type of sensor should I use?

A. A fast-response (low thermal mass) thermocouple.

18. What is the minimum immersion depth for a PRT probe?

A. Usually 150mm or more; increase the immersion until the reading is unchanged.

19. How do I accurately measure a surface temperature?

- A. Use a sensor designed specially for this or use an infra-red (non-contact) sensor instead.

20. What is the practical difference between wire-wound and film RTDs?

- A. Wire-wound type provides greater accuracy and stability but is vulnerable to shock; film type is resistant to shock and has quicker thermal response.

21. What do the thermocouple terms “cold junction compensation” and “linearisation” mean?

- A. Refer to this Labfacility Temperature Handbook for a full explanation. With most types of measuring instrument, these functions are automatically applied and do not require user consideration.

22. There are several different types of extension cable construction; is the choice important?

- A. Yes; some are waterproof, some mechanically stronger, some suitable for high or low temperature.

23. Is a sensor with a calibration certificate more accurate than an uncalibrated one?

- A. No. However, the errors and uncertainties compared with a reference sensor are published and corrected values can be used to obtain better measurement accuracy.

24. How long will my sensor last in the process?

- A. Not known but predictable in some cases; this will be a function of sensor type, construction, operating conditions and handling.

25. I need to use “fail-safe” alarms on my process. Can my controller and alarms share the same thermocouple?

- A. Use duplex sensors, one connected to the controller and the other to the alarm. Your controller may have alarms incorporated in which case you are relying on your control sensor.

26. Which thermocouple type do I need for my application?

- A. This depends on several factors including the nature of the process, heated medium and temperature. Refer to this Labfacility Temperature Handbook for guidance.

27. What is the longest thermocouple I can have without losing accuracy?

- A. Try to ensure a maximum sensor loop resistance of 100 Ohms for thermocouples and 4 wire PRTs. Exceeding 100 Ohms could result in a measurement error. Note By using a 4-20mA transmitter near the sensor, cable runs can be much longer and need only cheaper copper wire. The instrument must be suitable for a 4-20mA input though.

- 28. Do I need a power supply when using a transmitter, and what length of extension lead can I run with a transmitter fitted?**
- A. A 24Vdc, 20mA supply will be needed if this is not incorporated in the measuring instrument. Long runs of copper cable can be used.
- 29. What accuracy will I get at a certain temperature using a Pt100 detector; if a better grade detector is used what effect will this have to the accuracy?**
- A. Refer to this Labfacility Temperature Handbook for Pt100 tolerance information.
- 30. What sensor will I need to work in molten metal or a corrosive atmosphere?**
- A. There is no simple answer but special grades of Stainless Steel, Inconel 600, Microbell and Ceramics offer alternatives.
- 31. What accuracy loss will I get using a transmitter in line?**
- A. This depends on the accuracy of the specified transmitter; there will always be some degradation.
- 32. As most instrumentation only takes 2 or 3 wire Pt100s, if I took the correction made on the 3 wire system and incorporated that on to the single leg could I achieve a 4 wire system?**
- A. No; cable length and ambient temperature variations come into play.
- 33. Can I still purchase the old BS colour code and why has everything gone Over to IEC?**
- A. Some companies can supply some products to the "old" obsolete BS colour but the current IEC standard is internationally recognised.
- 34. What is the difference between a fabricated thermopocket and solid drilled Thermowell?**
- A. A fabricated thermopocket uses a welded construction to allow for relatively long immersion lengths; a thermowell is machined from solid material.
- 35. If I have a thermowell in my process; how much probe length do I allow for my Temperature sensor to suit?**
- A. An extra 50mm for a compression gland if used or probe length to fully seat into the well if a thread below head.
- 36. What typical pressure are thermowells / thermopockets rated to and what is the Thermal response time of the thermowell?**
- A. Typically tens of bar and tens of seconds more than the sensor. Refer to a full supplier specification however – values vary.

37. What is the difference between a flat film and wire wound Pt100 element?

A. Film uses platinum deposition on a substrate; wire wound uses a helically wound Pt wire in ceramic. Wire-wound type provides greater accuracy and stability but is vulnerable to shock; film type is resistant to shock and has quicker thermal response.

38. If copper can be used at the same point on each leg of a thermocouple can I use Copper connectors on thermocouples?

A. Yes but only if both legs are maintained at exactly the same temperature. Not recommended.

39. If I added two identical cable lengths to a simplex thermocouple sensor for two instrumentation Units will I get the same reading as using a duplex sensor?

A. Yes, provided the instrument inputs are truly potentiometric and no measuring current is drawn. Not recommended.

40. Why should I use an insulated hot junction sensor with instrumentation?

A. To eliminate the possibility of earth loops resulting in measurement errors and to reduce the danger of voltage pick up from electrical heaters.

41. What is Automatic Cold Junction Compensation?

A. This is a feature of most measuring instruments which allows for the fact that the thermocouple input termination is at varying temperature other than stable at 0°C.

Remember, the sensor type must always suit the measuring instrument and employ the correct extension cable. Information given here is for general guidance only and is not definitive – it is not intended to be the basis for product installation or decision making. Labfacility Ltd can not be held responsible for any misinterpretation or incorrect assumptions based on these Questions and Answers.

13. INDEX

A

Alarms	75,76
Analogue retransmission.....	67
Approach Optimisation	73
Automatic cold junction compensation.....	63,64

B

Barrier terminals	52
Base metal wire and cable - types.....	19,20,78
- tolerances	79
Bridge circuits	28,29

C

Cable	- compensating	12,15,17,78,79,80
	- extension	12,15,17,78,79,80
Calibration	- electrical	53,58
	- system, general purpose	54
	- system primary standards	54
	- system secondary standards.....	54
	- temperature.....	53,54,55,56
	- thermal	53,54,55
Calibrators	- dry block	55
Ceramic sheath.....		43,45,46
Certification.....		54
Closed loop		59,60,64,65,69
Coefficients	- polynomial, Pt100	25
Cold junction compensation		63,64
Comparison	- thermocouple v. resistance thermometer	
	v. thermistor.....	9
Conductor size equivalents.....		81
Connecting thermocouples to instruments		50
Connection configurations – Pt100		32,83
Connections (connectors)		16,50,51,52
Construction of industrial probe		41
Control.....		62,64,65,69-76
Control loops explained.....		69
Control outputs		65,75
Conversion tables °C / °F		109

D	
Data Acquisition	63,66
Data Communications	67
Data Logging	63,66
Derivative term.....	72,73,74
Different thermocouple types.....	19,20,86-108

E	
Electrical resistivity	38
Electromagnetic Compatibility	68
EMC and EMI.....	68
Exposed junction	14
External reference junctions.....	13

F	
Fittings	49,50
Fixed temperature points.....	57,110
Frequently asked questions.....	128
Fundamental interval.....	26
Fuzzy Logic	73

G	
Glossary of terms	117-126
Grades of protection for enclosures.....	111,112

H	
Heat – Cool	73
High accuracy measurement – resistance thermometers.....	35
High accuracy measurement – thermocouples.....	22
Hot box.....	13

I	
Ice point.....	13
Immersion length	23,24
Indicators, temperature – precision.....	56,57
Infra-red pyrometry.....	39,40
Insert.....	42
Instrumentation.....	59-68
Instrument Protection (IP) ratings.....	111,112
Insulated junction	21
Insulated wire sizes.....	82
Insulations – Wire & Cable	17,33
Integral term	72,73,74
International and National standards.....	114,115,116
IPTS 68.....	110

Isothermal systems	14,55
ITS 90.....	110

J

Junction	- exposed	14
	- insulated	14
	- measuring	10,11
	- reference	10,11,13

L

Lagging extensions.....	49	
Loop	- closed.....	59,60-64,65,69
	- open	59,69
Loop resistance – thermocouple wire.....	83	

M

Measuring junction.....	10,11
Metal film resistors	31,32
Mineral insulated thermocouples.....	21,22

N

Nominal resistance	26
Non-contact thermocouple.....	39,40
NTC thermistor.....	37,38

O

On-off.....	70
Open loop.....	59,69
Optical pyrometry	39
Optimising control terms.....	74
Overall accuracy.....	60

P

Parallel Communications	67	
PID explained.....	70-73	
Polynomial – resistance thermometer	25,26	
Problem solving chart.....	113,114	
Problem solving in temperature measurement & control	113,114	
Process connections.....	47	
Process variable	70	
Proportional band.....	71,72,73,74	
Proportional term	71	
Pt100	- characteristics	84,85
	- connection colour codes	32.83
	- tolerances	83

R		
Reference data	- thermocouple thermometry.....	77-82
	- platinum resistance thermometry.....	83
Reference junction.....		10,11,13
Reference section.....		77-116
Resistance temperature characteristic		26,84,85
Resistance thermometer.....		25-36
Resistance thermometer	- theory.....	25,26,27
	- terminating.....	27-29,32
	- self heating.....	34
	- high accuracy	35,36,56
Resistivity – electrical.....		38
Resistors (sensing)	- metal film.....	31
	- platinum sensing.....	31
	- wire wound	31
Response time	- thermocouples.....	22,23

S		
Sampling rate		66
Self-heating.....		34
Serial Communications		67
Set-point		70
Sheath material – application guide.....		43,44,45
Sheath	- ceramic.....	45
	- metallic.....	45
	- non-metallic.....	45
Signal conditioning.....		62
Simulators / sources		55,58
Surface temperature – thermocouple		24
	- Pt100.....	30

T		
Tables	- conversion °C/°F	109
	- Pt100 Ω / °C.....	84,85
	- Thermocouple mV / °C.....	86-108
Temperature	- calibration	53-58
	- control.....	62,63,64,65,69-76
	- conversion table °C / °F	109
	- indicators , precision	56,57
	- measurement.....	62,63
	- sources	55
	- thermodynamic.....	3,110
Terminal head.....		42,43
Termination colour codes – Pt100		32,83
Terminations.....		52

Thermocouple	10-24
Thermocouple	- accuracies22,77,79
	- cable colour codes140
	- characteristics86-108
	- construction14
	- different types19,20
	- fabricated21
	- mineral insulated21,22
	- platinum20
	- terminating15,17,18,19
	- theory10,11
Thermistor	- Alpha coefficient37
	- beta value38
	- NTC37
	- self-heating39
Thermoelement	10,11,12
Thermometers	- high accuracy measurement resistance35,36
	- standard platinum resistance56
	- terminating resistance27,28,29,32
Thermometry fixed points	57,58,110
Thermopile (infrared).....	40
Thermopocket	46,47,48
Thermowells	46,47,48
Tolerance table	- Pt100.....83
	- thermocouples77
	- thermocouple wire79
Transmitters.....	30,59,61,62
 W	
Wheatstone bridge.....	28,29
Wire & cables	- conductor size equivalents81
	- insulated wire sizes82
	- loop resistance83
	- single & multi-strand82
Wire-wound Pt100 resistor.....	31

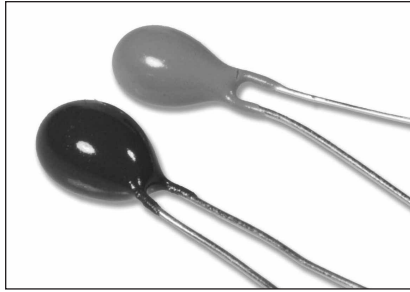

NTC thermistors

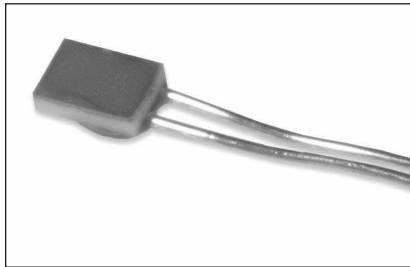

Miniature RTD sensor

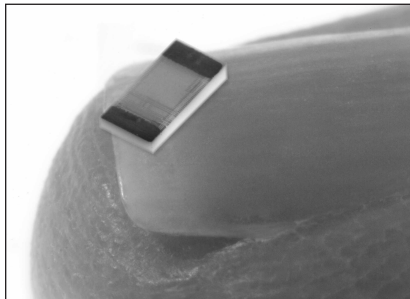

Surface mount RTD sensor